

# INTERACTION IN VISUALIZATION

Petra Isenberg

# RECAP

- Interaction is fundamental to the definition of visual exploration
- You have already seen examples
  - for graphs
  - for time series
  - for multi-dimensional data

# RECAP

- Visual exploration is more than just looking

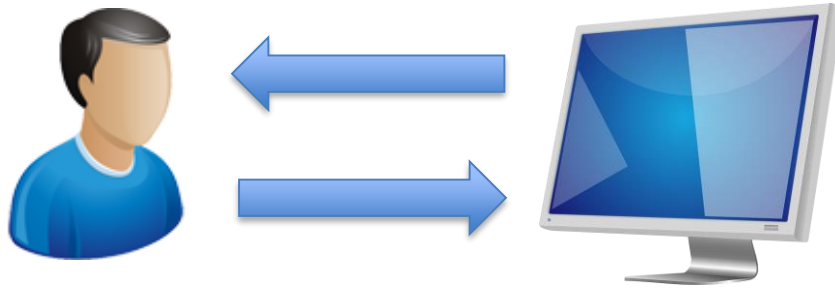

- So far we focused mostly on output
  - but we have already used limited input earlier in the course
- Today: input for steering visual output

**WHY INTERACT?**

# DEFINITION OF INTERACTION

- Static content
  - many infographics
- Dynamic content
  - Animated content  
Changes independently from the user
  - Interactive content  
Changes as a result of user actions

# PERCEPTION

LATERAL  
MOTION



PRESSURE



STATIC  
CONTACT



UNSUPPORTED  
HOLDING

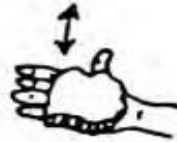

ENCLOSURE



CONTOUR  
FOLLOWING



FUNCTION  
TEST



PART MOTION  
TEST



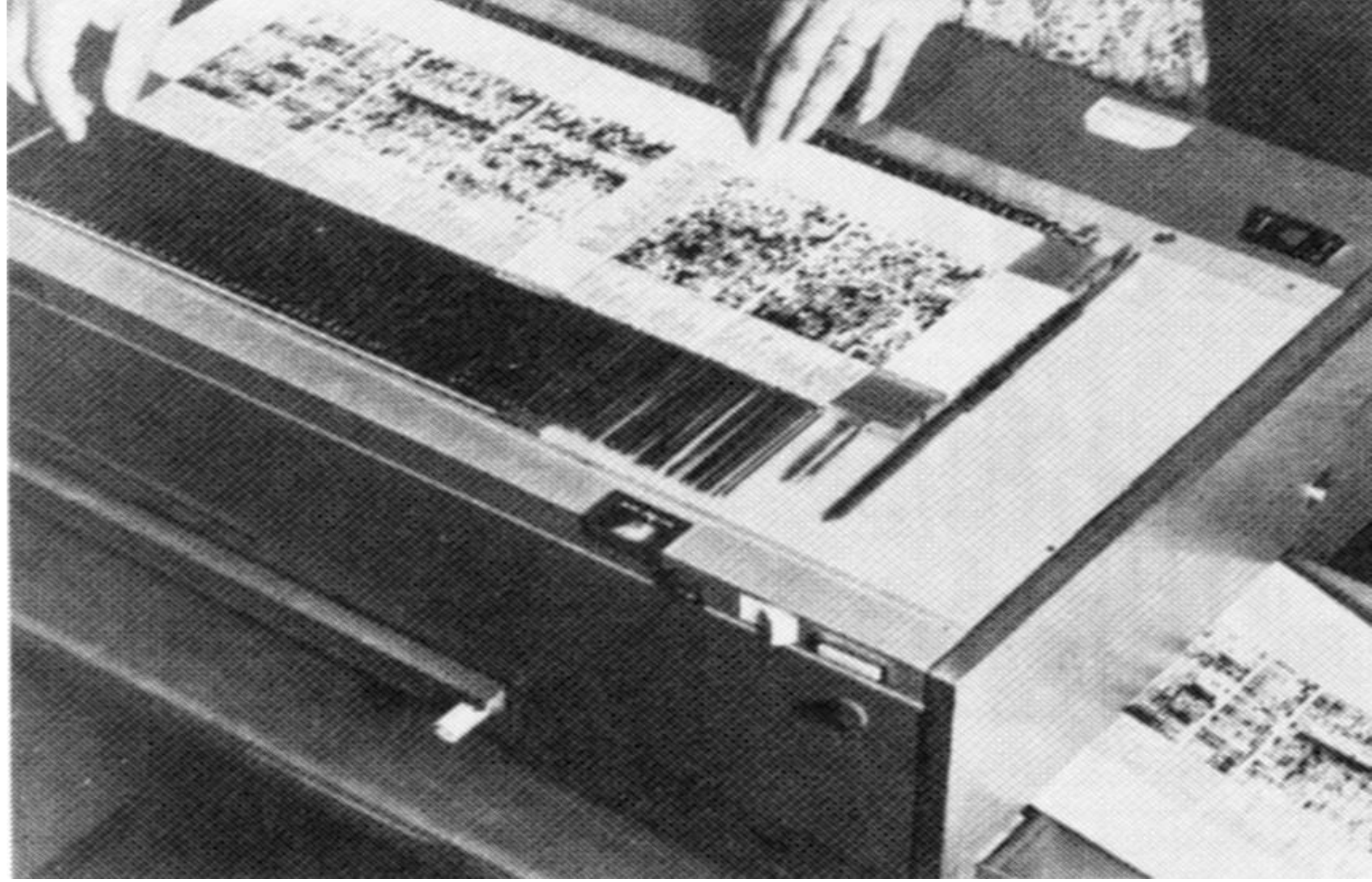

- THERE IS TOO MUCH DATA TO SHOW
- THERE ARE MANY WAYS TO SHOW IT

LET THE USER DYNAMICALLY CONTROL WHAT TO SHOW AND HOW



# NOT TOO LONG



1970s

# TAXONOMIES OF INTERACTION

- What?
  - What is the user doing?
- Why?
  - Why is the user doing it?
- How?
  - How is the user doing it?

# THE VISUALIZATION PIPELINE

# THE VISUALIZATION

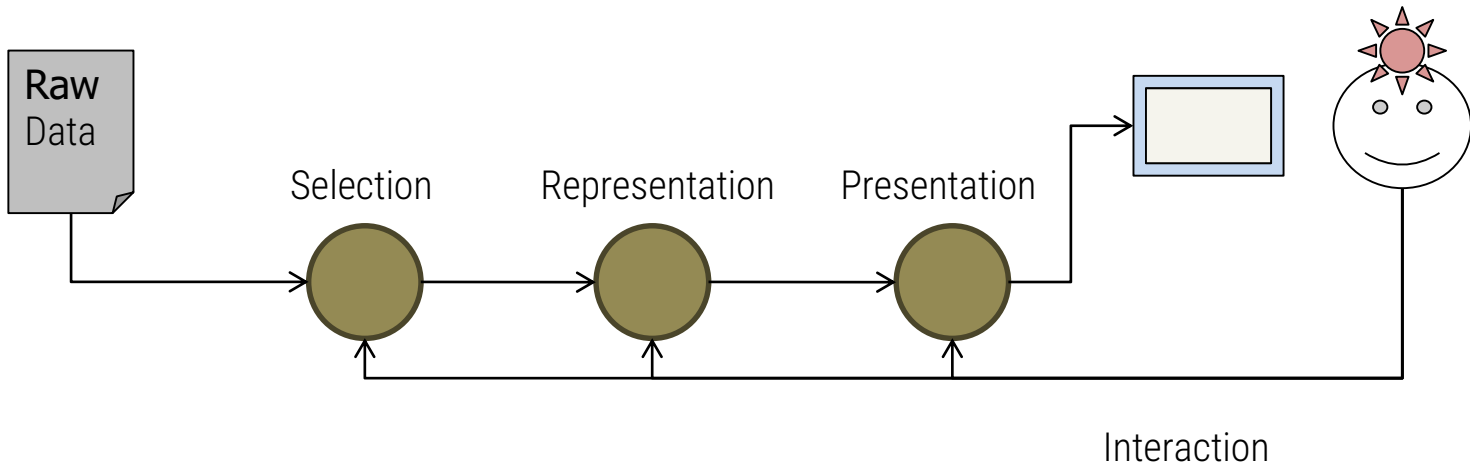

The Visualization Pipeline

# THE VISUALIZATION PIPELINE

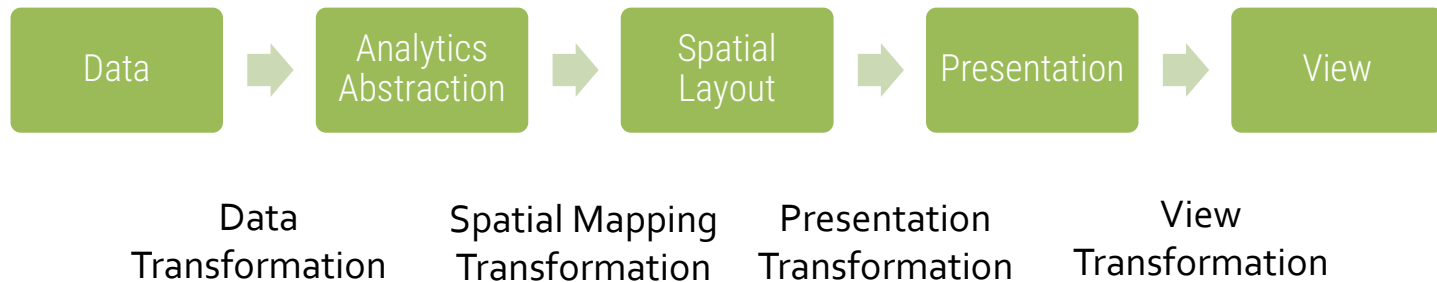

# THE VISUALIZATION PIPELINE

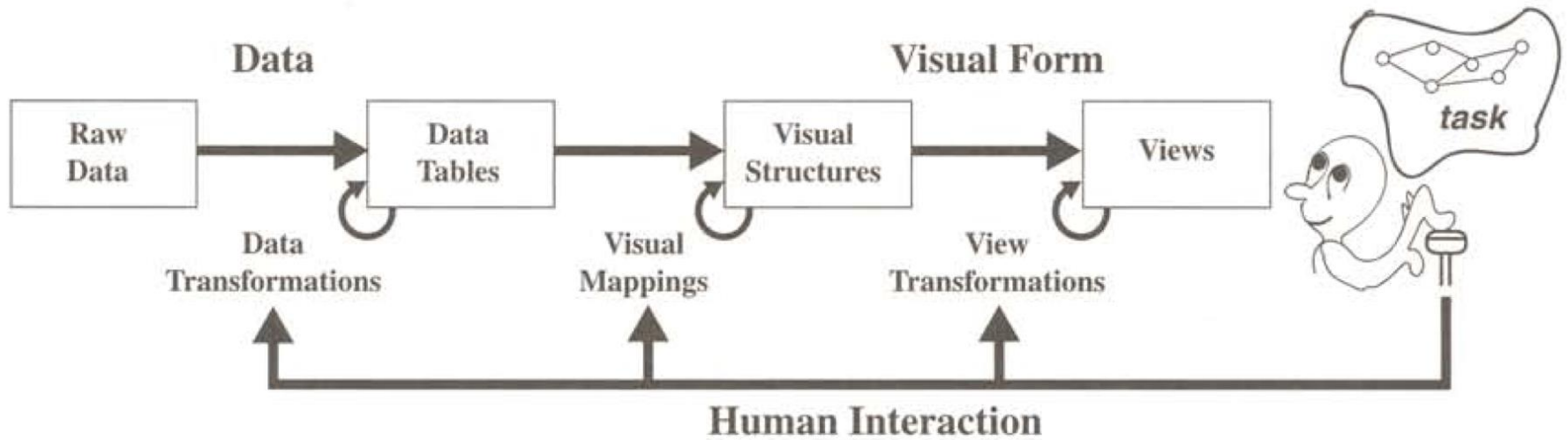

**Raw Data:** idiosyncratic formats

**Data Tables:** relations (cases by variables) + metadata

**Visual Structures:** spatial substrates + marks + graphical properties

**Views:** graphical parameters (position, scaling, clipping, ...)

# THE VISUALIZATION PIPELINE

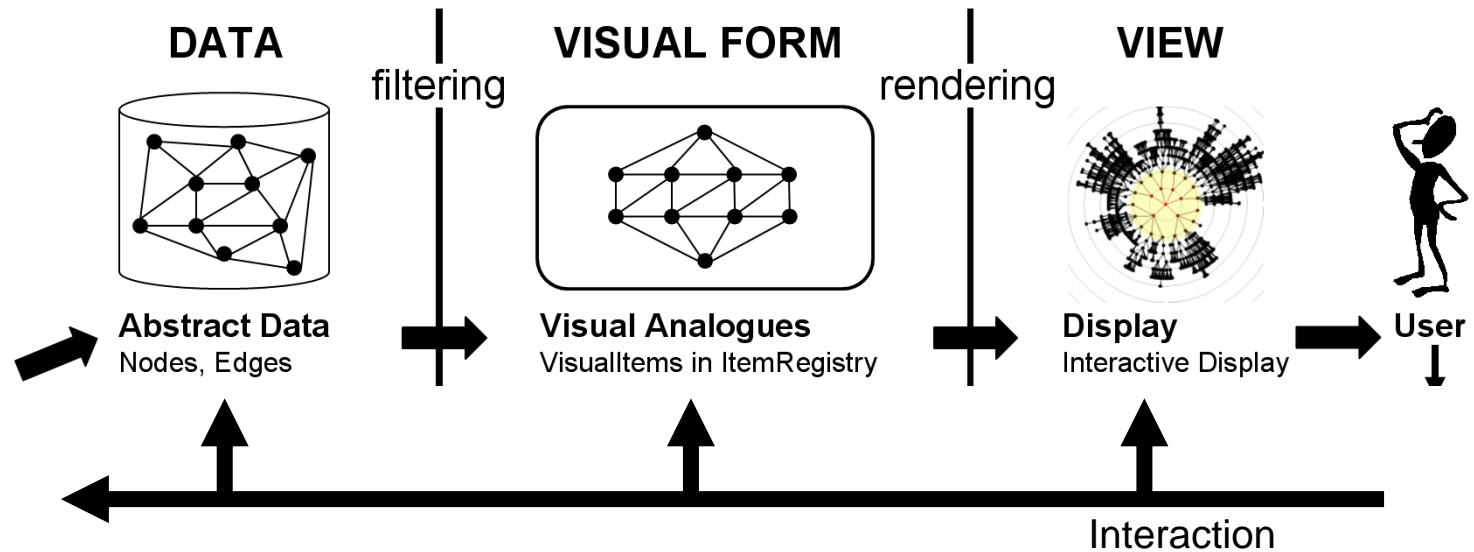

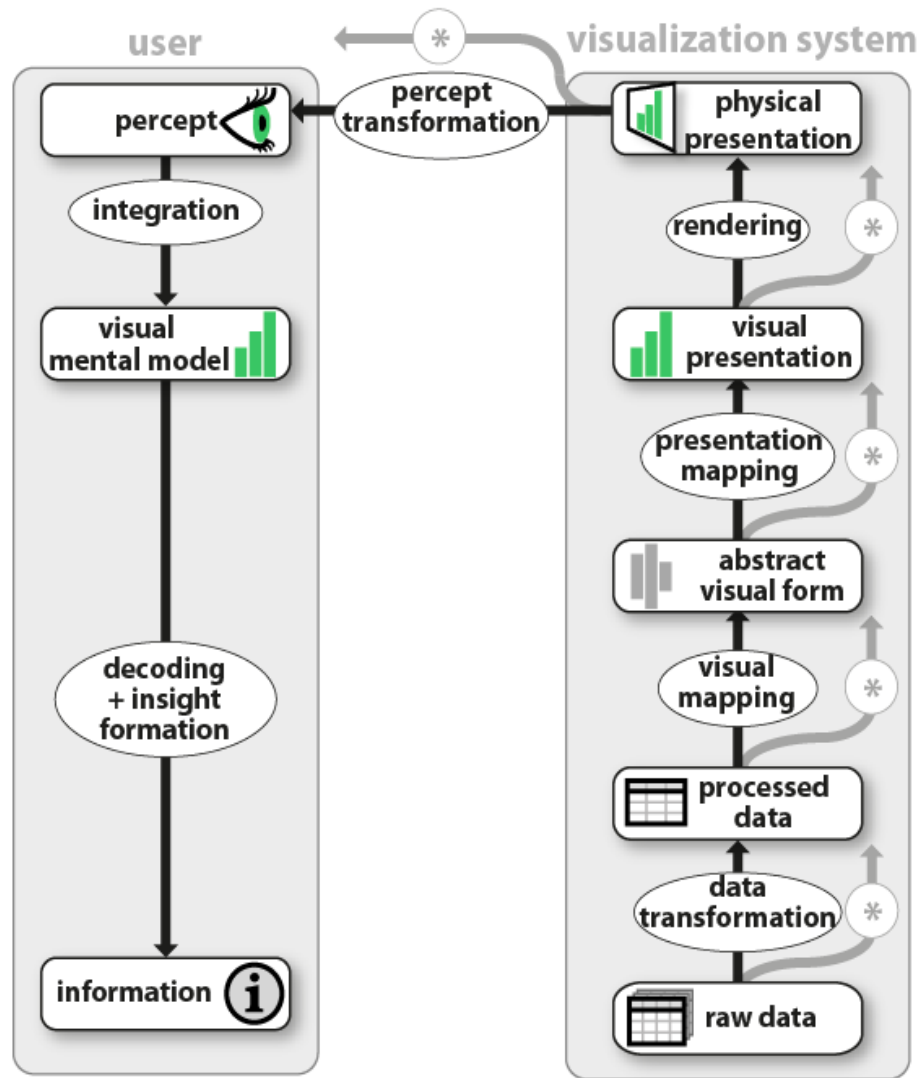



# GAPMINDER for a fact-based world view

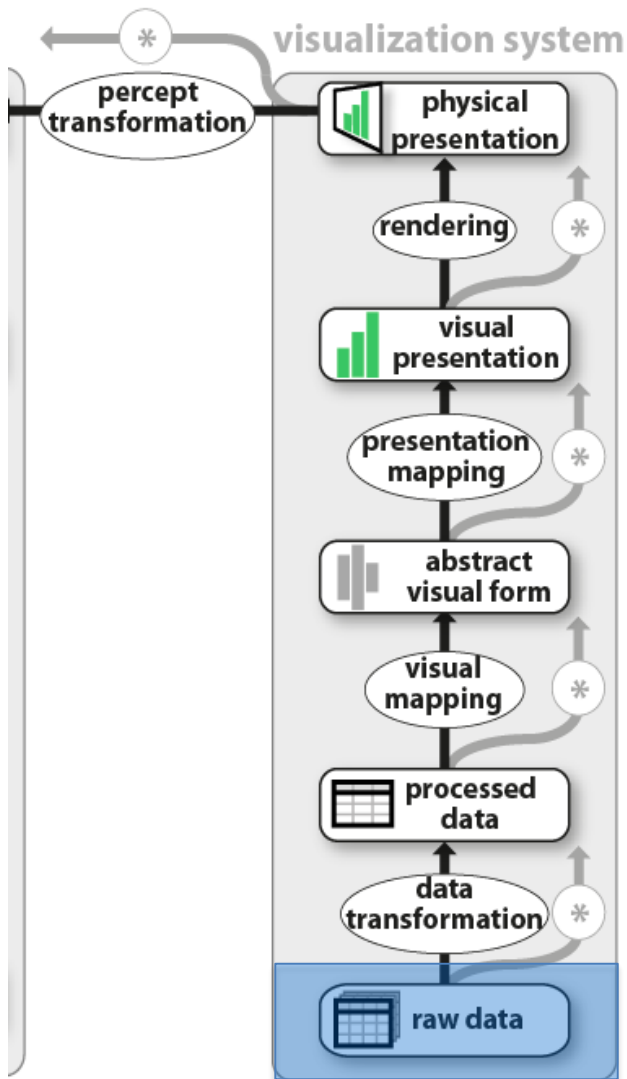

	A	B	C	D	E	F	G	H	I	J	K	L	M	N	O	P	Q	R	S	T	U	V	W	X	Y	Z	AA	AB	AC	AD	AE	AF	AG	AH	AI	AJ	AK	AL	AM	AN	AO	AP	AQ				
1	Education aid (% of total aid)	1967	1968	1969	1970	1971	1972	1973	1974	1975	1976	1977	1978	1979	1980	1981	1982	1983	1984	1985	1986	1987	1988	1989	1990	1991	1992	1993	1994	1995	1996	1997	1998	1999	2000	2001	2002	2003	2004	2005	2006	2007	2008	2009			
2	Australia	4.7	3.3	2.0	2.4	2.8	3.0	1.1	1.2	1.1	2.0	2.4	2.5	2.1	4.9	5.0	4.5	4.1	3.9	3.4	4.7	3.9	2.3	2.9	2.1	2.9	2.8	2.8	2.7	2.3	1.4	1.1	1.0	0.7	1.1	0.9	1.2	1.2									
3	Austria	29	42	13	2.5	1.6	4.9	1.9	1.7	4.5	1.8	7.6	0.7	1.5	3.2	4.4	3.0	3.2	1.6	1.2	3.1	3.2	2.4	2.9	3.1	4.5	2.5	4.9	3.9	2.9	4.3	3.3	4.0	4.1	3.9	3.9	4.1										
4	Belgium	85	84	11	1.1	1.9	1.9	2.7	2.2	2.0	2.0	6.8	4.5	1.6	3.7	3.7	3.4	2.8	2.4	3.0	2.2	1.8	1.9	1.7	2.2	1.4	1.5	2.0	2.1	2.0	1.9	2.2	2.0	2.6	2.0	1.9	2.1	2.5									
5	Canada	34	39	1.8	2.9	8.4	15.1	8.4	3.3	4.4	1.7	2.2	8.7	8.4	7.1	1.6	3.0	1.9	1.2	2.0	3.6	1.4	1.1	1.5	1.9	1.4	1.1	1.3	4.2	7.9	4.3	1.1	7.8	1.6	1.1	4.9	1.3	5.5	9.2	9.6	2.1	5.6					
6	Denmark	100	100	1.4	1.9	5.6	1.5	3.8	1.4	8.2	9.5	1.4	0.5	5.8	1.0	3.7	3.3	3.7	4.6	1.5	1.3	1.4	1.1	1.3	4.2	7.9	4.3	1.1	7.8	1.6	1.1	4.9	1.3	5.5	9.2	9.6	2.1	5.6									
7	Finland	36	14	2.0	1.6	1.5	6.8	3.7	3	4.8	5	4.5	3.3	7.9	6.2	5.7	6.1	6.8	3.6	5.8	6.3	1.0	5.3	1.1	6.6	1.4	1.2	1.2	1.4	1.6	2.8	1.0	8.4	7.6													
8	France	63	64	4.7	3.9	3.8	3.8	4.0	3.9	4.2	4.5	3.0	3.3	3.8	3.5	3.4	2.8	3.0	2.8	3.2	3.4	3.6	3.6	3.9	4.0	3.3	3.9	4.3	4.4	4.7	3.6	3.7	4.1	4.2	4.1	4.0	3.8	3.7									
9	Germany	55	55	2.2	1.9	2.4	1.9	1.9	2.0	1.7	1.9	1.7	2.0	2.1	2.4	2.6	2.2	1.9	2.0	2.2	2.1	2.3	2.1	2.5	2.5	2.5	2.1	2.0	2.5	2.2	2.6	2.1	2.5	2.6	2.4	6.9	2.4	2.4									
10	Greece																																														
11	Ireland																																														
12	Italy	20	96																																												
13	Japan	13	12	2.9	1.1	2.2	2.6	2.9	3.2	2.9	3.1	3.6	3.7	5.1	6.8	1.1	7.7	6.1	6.6	9.8	8.8	8.5	6	10	6.5	6.9	7.9	13	7.6	9.5	13	15	13	15	8.8	11	8.1										
14	Luxembourg																																														
15	Netherlands	42	33	12	15	11	12	12	13	11	16	17	16	17	19	13	7.4	10	11	20	29	8.7	5.1	1.5	6.1	1.2	1.4	1.8	2.0	1.6	1.7	1.8	1.9	1.8	1.9	2.1	2.9	2.2									
16	New Zealand	30	21	5.1	8.8	2.8	2.0	1.7	1.9	1.9	1.7	1.9	1.5	1.3		4.7	6.8	1.5	4.8	5.1	6.0	2.0	2.2																								
17	Norway	55	49	3.2	9.7	5.7	7	13	5.9	5.5	2.8	2.6	2.5	8.7	7.5	11	8.8	12	3.1	1.4	7.8	8.2	7.3																								
18	Portugal																																														
19	Spain																																														
20	Sweden	33	23	1.5	1.4	2.1	1.8	1.7	2.1	1.7	6.8	1.6	1.7	1.7	1.2	1.5	3.6	1.3	1.5	6.5	8.7	1.4	7.6	9.7	11	13	1.2	1.4	1.0	1.1	5	6.2	1.1	8.9	11	8.9	8.5	8.4									
21	Switzerland	47	48	12	15	8.7	11	15	19	15	13	13	12	12	11	17	5	13	13	1.7	16	12	13	15	10	11	7.2	8.4	6.6	8	7.1	7.4	6.8	6.4	8.1	7.2	7.1										
22	United Kingdom	50	32	1.6	1.6	0.9	0.7	2.0	1.3	8.8	2.1	2.7	1.9	1.6	1.3	2.8	1.7	1.7	1.8	2.0	1.8	1.8	2.1	2.0	2.0	1.6	1.7	1.3	1.6	1.2	1.6	0.7	1.5	1.5	1.4	1.3	1.8										
23	United States	69	64	1.0			7.8	6.2			7.5	7	12	10	5.9	7.1	11	11	10	12	13	14	11	11	11	11	11	11	8	8.5	8.4	4.7	3	5.7	5.6	3.7	2.3	3.2	3.7	2.8	4.5						

	A	B	C	D	E	F	G	H	I	J	K
1	Education aid (% of total aid)	1967	1968	1969	1970	1971	1972	1973	1974	1975	197
2	Australia	4.75	33.2	19.7	23.7	26.3	30.				
3	Austria	24.7	42.3	13.5	2.52	15.9	4.8				
4	Belgium	84.5	83.7	11	11.4	15.9	18.				
5	Canada	33.7	38.6	18	25.3	8.41	5.1				
6	Denmark	100	100	13.7	19	5.6	15.				
7	Finland							29.6	13.5	14.1	20.
8	France	62.9	63.7	46.8	33.4	38.2	38.				
9	Germany	54.6	54.8	21.7	18.8	23.6	18.				
10	Greece										
11	Ireland										
12	Italy	20.1	95.8							39.5	
13	Japan	12.6	12.3	2.92	1.08	2.15	2.5				
14	Luxembourg										
15	Netherlands	42	32.6	12.4	15	1					
16	New Zealand							19.5	20.9	5.15	8.8
17	Norway	54.7	48.8	32.4	9.71	5.74	7.0				
18	Portugal										
19	Spain										
20	Sweden	32.6	23.4	15	13.7	20.7	18.				
21	Switzerland	47	46	12	15	8.7	11.				
22	United Kingdom	49.8	32.4	15.9	16.2	0.91	0.				
23	United States	69.3	64	9.97						7.76	6.1
24											

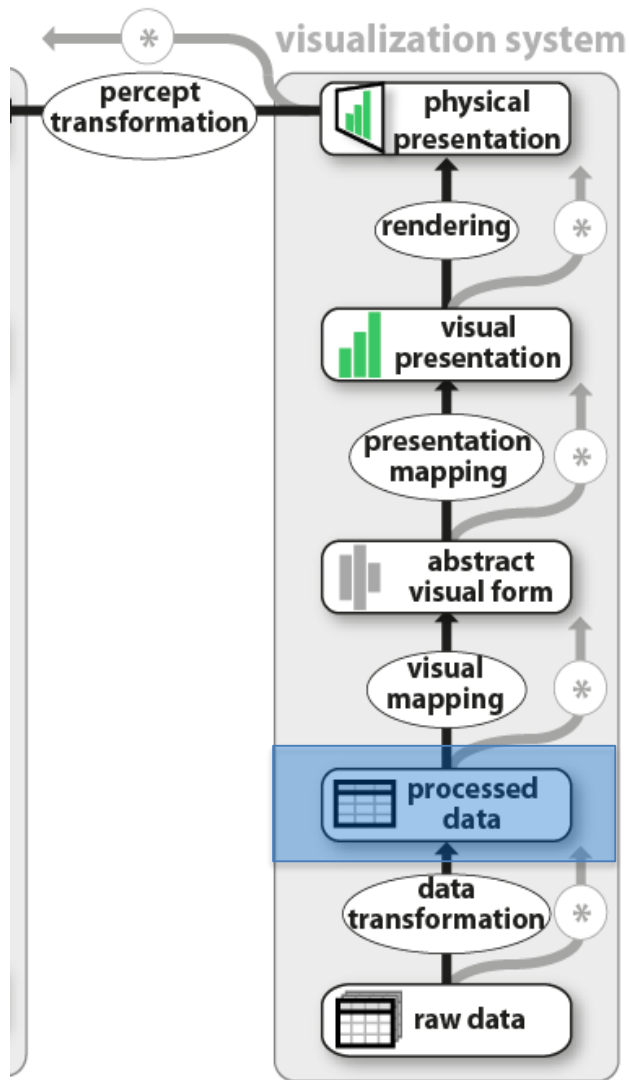

	A	B	C	D	E	F	G	H	I	J	K
1		1989	1990	1991	1992	1993	1994	1995	1996	1997	1998
2	Austria	12.23	31.86	31.07	31.57	24.02	28.61	30.52	44.99	35.41	48.95
3	France	31.87	34.18	35.95	36.06	38.78	40.18	32.68	39.26	43.15	43.9
4	Australia	33.57	46.93	39.24	23.18	38.94	21.38	29.1	29.43	27.97	28.32
5	Belgium	29.93	22.13	17.64	18.52	17.72	17.13	21.77	13.63	14.69	20.38
6	Canada	28.11	25.09	14.35	11.19	9.291	21.67	17.33	13.98	25.19	15.66
7	Netherlands	10.78	20.12	29.08	8.702	5.085	15.12	9.117	12.48	13.75	18.17
8	Italy	6.278	9.992	9.04	6.076	15.66	12.26	16.75	11.75	10.75	17.98
9	Denmark	1.485	1.933	13.52	10.71	13.01	4.193	7.937	4.303	11.42	7.581
10	United States	13.69	11.25	11.22	11.22	11.22	7.992	8.465	8.409	4.702	3.038
11	Norway	14.25	7.561	8.219	7.255	3.967	4.307	4.476	10.99	14.62	9.296

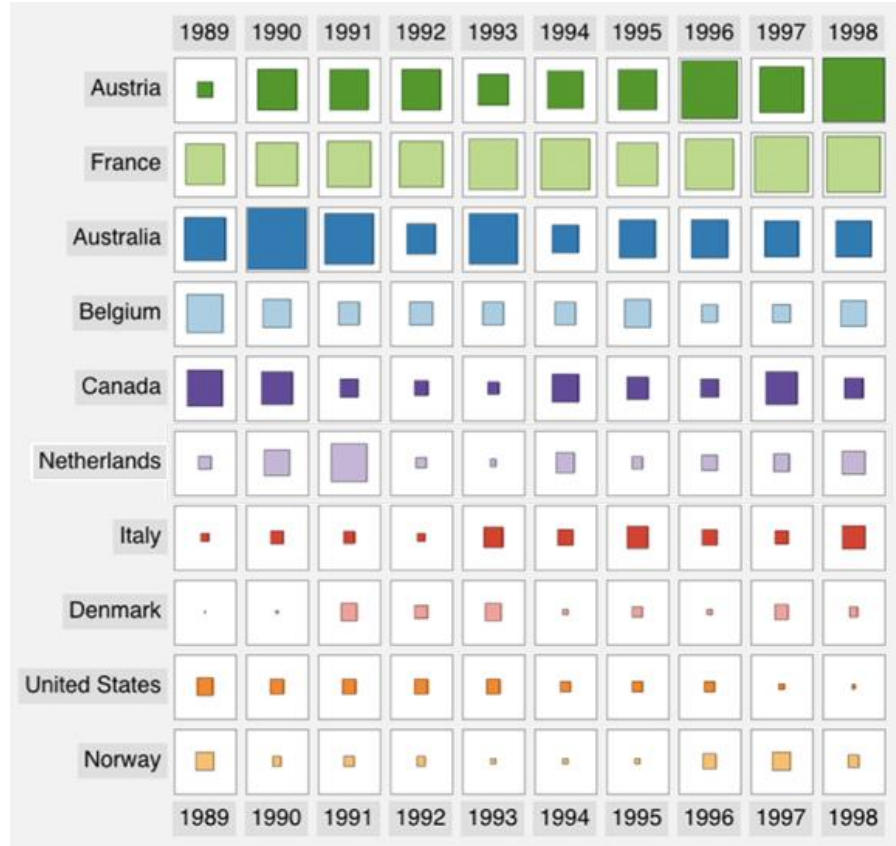
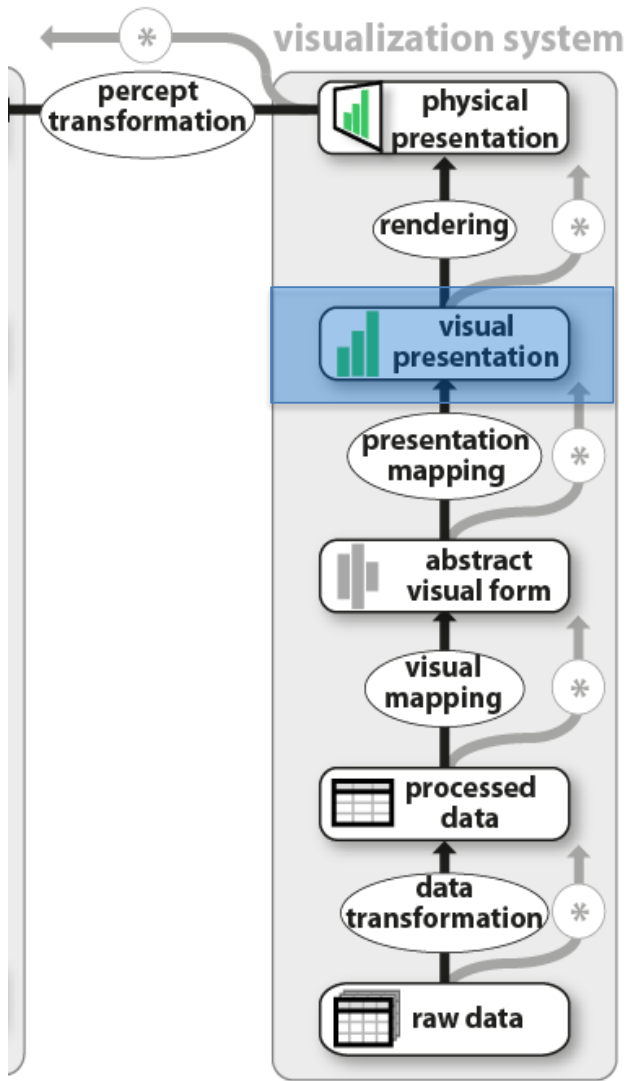

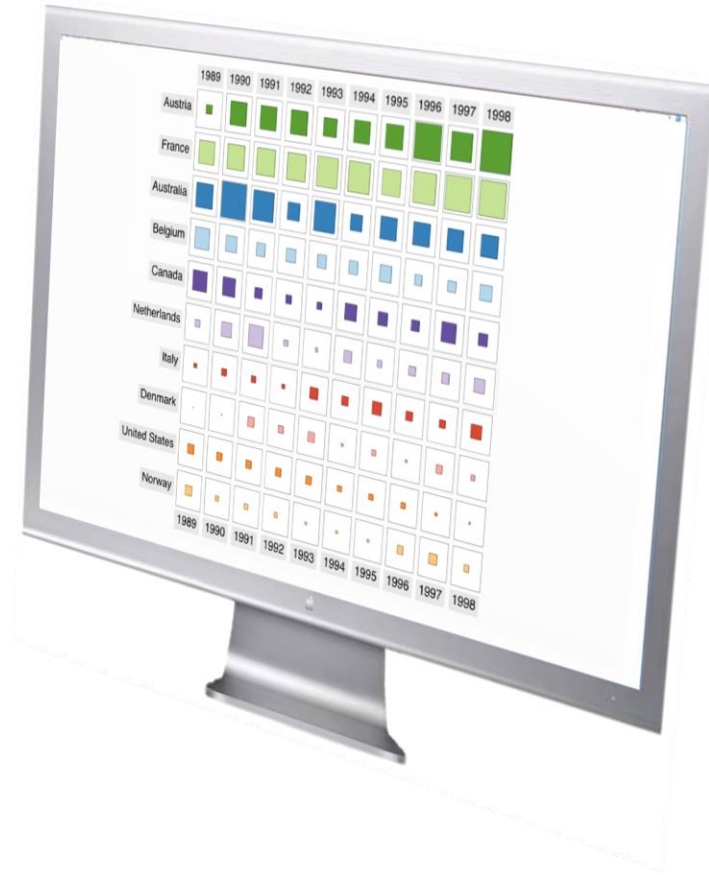
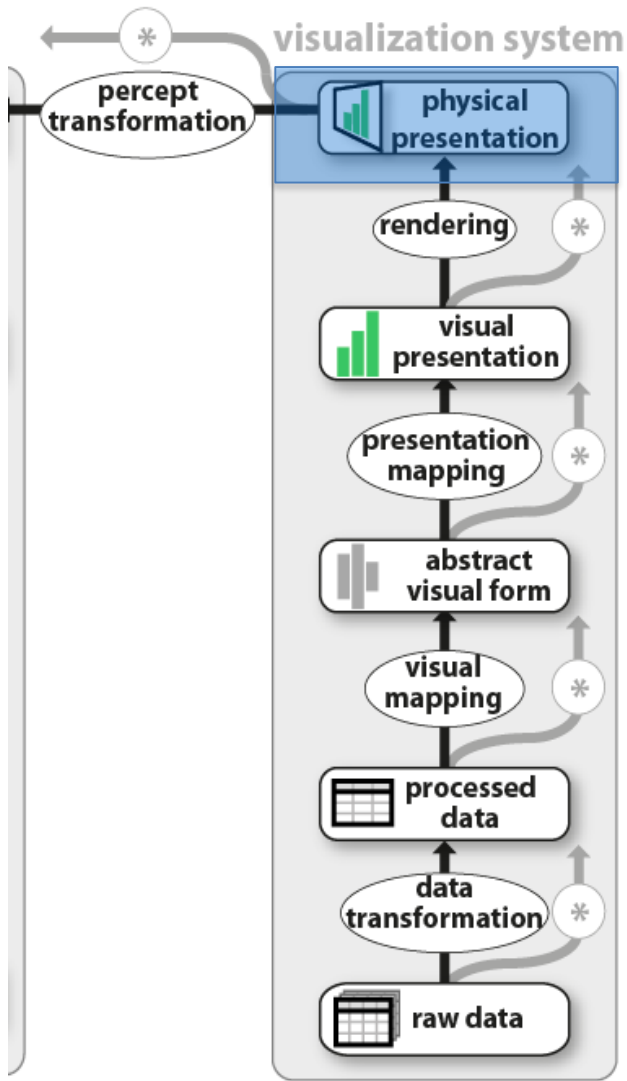

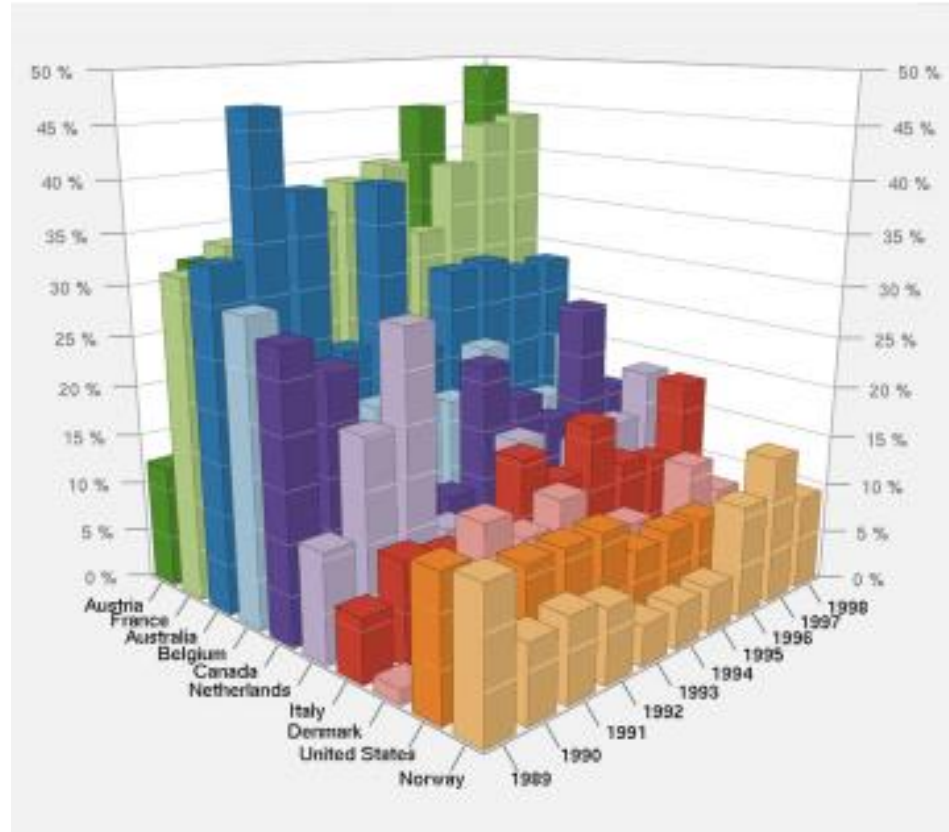
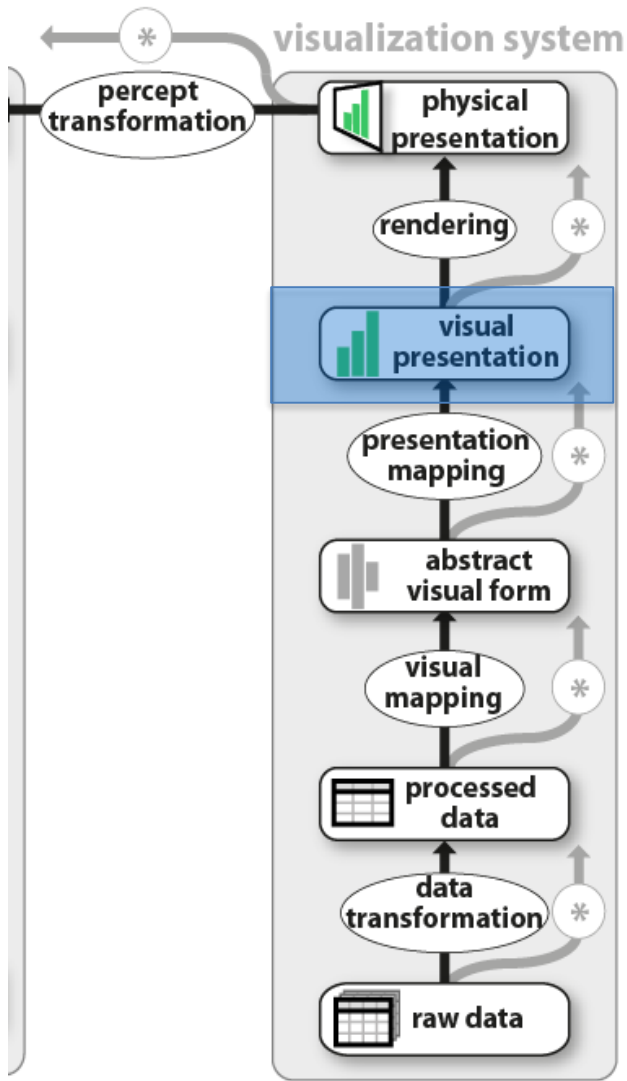

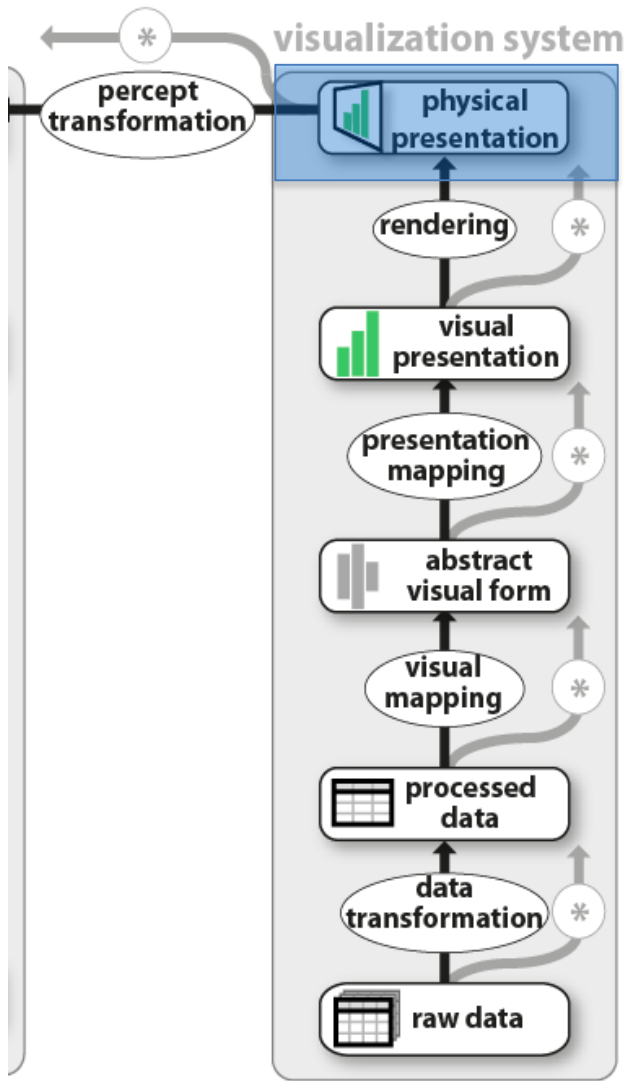

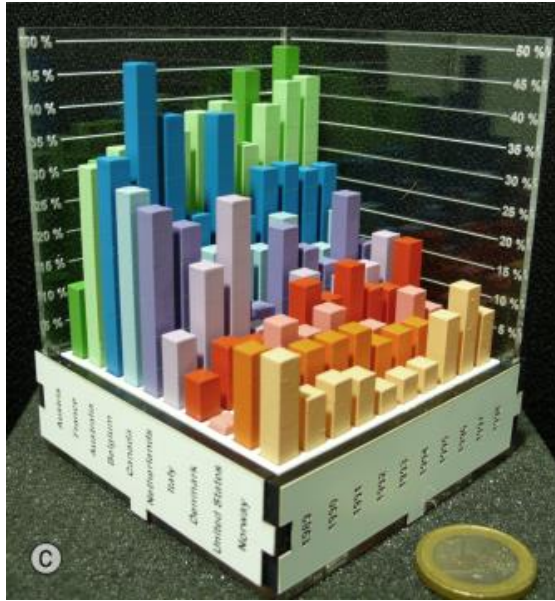
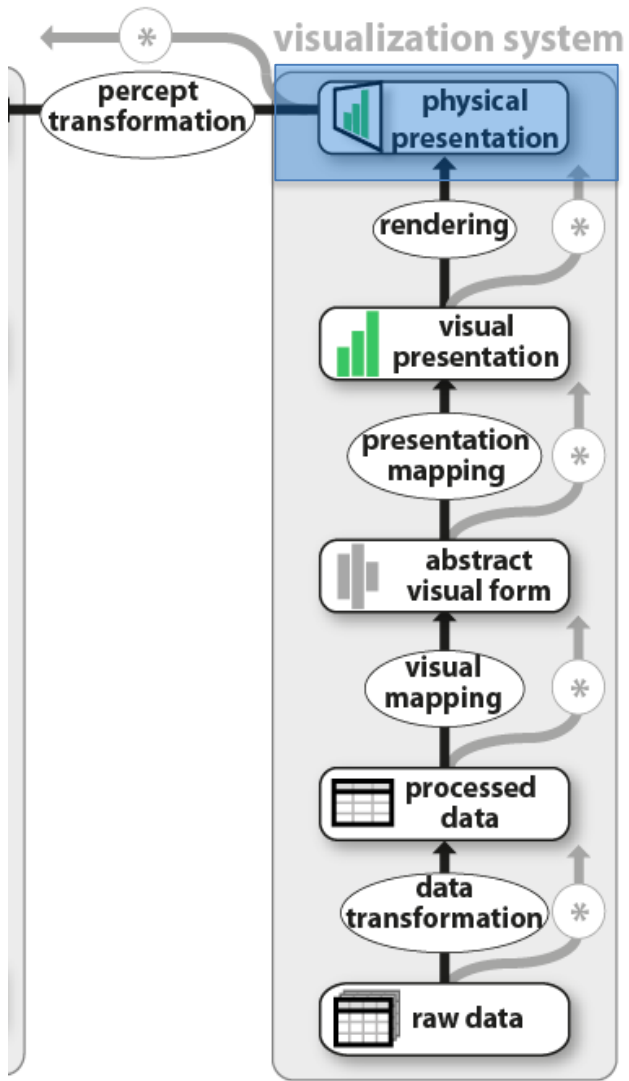

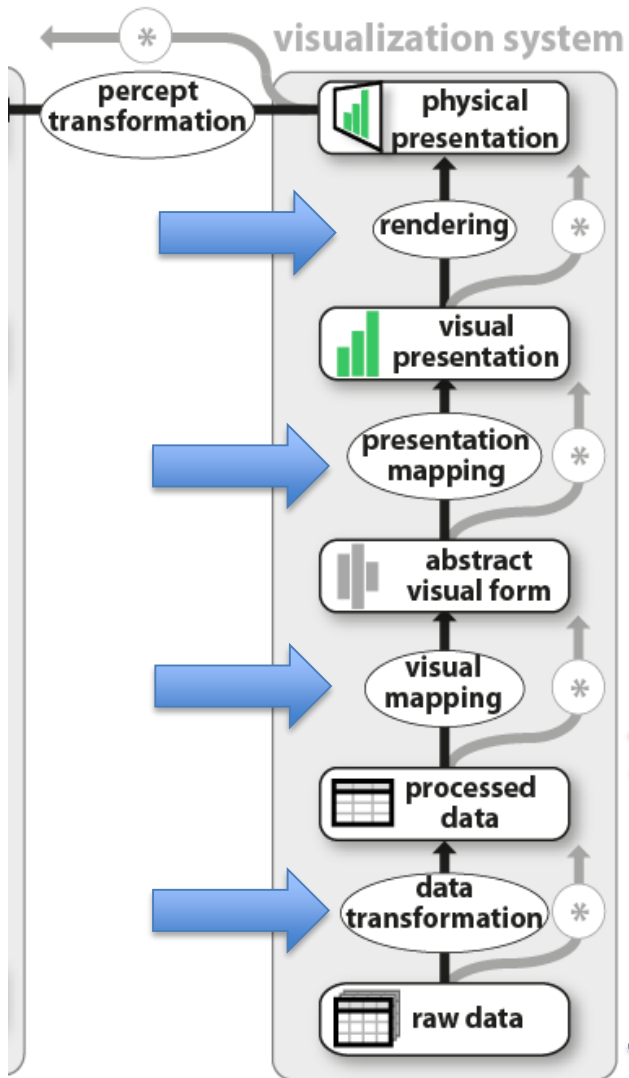

(view level)

(visual level)

(data level)



	A	B	C	D	E	F	G	H	I	J	K	L	M	N	O	P	Q	R	S	T	U	V	W	X	Y	Z	AA	AB	AC	AD	AE	AF	AG	AH	AI	AJ	AK	AL	AM	AN	AO	AP	AC										
1	Education and health	1967	1968	1969	1970	1971	1972	1973	1974	1975	1976	1977	1978	1979	1980	1981	1982	1983	1984	1985	1986	1987	1988	1989	1990	1991	1992	1993	1994	1995	1996	1997	1998	1999	2000	2001	2002	2003	2004	2005	2006	2007	2008										
2	Australia	4.7	3.3	2.0	2.6	2.8	3.0	1.1	1.2	1.1	2.0	2.4	2.5	2.1	4.8	5.0	4.5	4.1	3.9	3.4	4.7	3.8	2.3	3.9	2.1	2.9	2.9	2.8	2.8	2.7	2.3	1.4	1.1	1.0	0.7	0.1	1.2	1.2															
3	Austria	29	42	13	2.5	16	4.5	19	17	4.5	18	7.6	0.7	1.5	32	44	30	32	1.6	12	32	31	32	24	29	31	45	35	48	36	29	43	33	40	41	39	29	41															
4	Belgium	85	84	11	11	16	19	27	22	20	20	6.8	4.5	1.6	37	27	34	28	24	20	22	18	19	18	17	22	14	15	20	21	20	19	22	20	26	19	21	25															
5	Canada	34	39	18	25	18.4	5.1	8.4	3.3	3.4	1.1	7.2	9.7	9.4	7.1	1.6	10	19	12	28	25	1.5	11	9.3	22	17	14	25	1.6	1.9	19	20	26	16	16	18	11																
6	Denmark	100	100	14	19	5.6	15	3.8	14	8.2	9.5	14	0.5	5.8	10	3.7	3.3	3.7	4.6	1.5	1.9	14	11	13	4.2	7.9	4.3	11	7.6	1.6	11	4.9	13	5.5	8.2	9.6	21	5.6															
7	Finland	30	14	1.2	25	1.6	1.5	8.6	3.7	3	4.8	5	4.5	3.5	7.9	6.2	3.7	3.1	6.8	3.6	8.8	5.3	10	5.3	11	8.6	14	13	12	14	15	34	10	8.4	7.6																		
8	France	63	64	47	33	38	38	40	39	42	45	30	33	35	34	26	30	28	32	34	38	36	39	40	33	39	43	44	47	38	37	41	42	41	40	38	37																
9	Germany	55	55	22	19	24	19	19	20	17	19	17	20	20	21	24	26	22	19	20	22	21	25	21	25	25	21	20	25	22	24	21	25	26	24	19	25	24															
10	Greece																																																				
11	Ireland																																																				
12	Italy																																																				
13	Japan	13	12	2.9	1.1	2.2	2.6	2.9	3.2	2.9	3.1	3.6	3.7	7.1	6	8.8	11	7.7	6.1	8.6	9.8	8.8	8.5	8	10	10	6.5	6.9	7.8	13	7.6	9.5	13	15	8.8	11	8.1																
14	Luxembourg																																																				
15	Netherlands																																																				
16	New Zealand																																																				
17	Norway																																																				
18	Portugal																																																				
19	Spain																																																				
20	Sweden																																																				
21	Switzerland																																																				
22	United Kingdom																																																				
23	United States																																																				
24																																																					



# TAXONOMIES OF INTERACTION

- What?
  - What is the user doing?
- Why?
  - Why is the user doing it?
- How?
  - How is the user doing it?

## Tasks

# INTERACTION AS TASKS

# ANALYTIC TASKS

BEN SHNEIDERMAN 1996



1. **OVERVIEW:** GAIN AN OVERVIEW OF THE ENTIRE COLLECTION
2. **ZOOM:** ZOOM IN ON ITEMS OF INTEREST
3. **FILTER:** FILTER OUT UNINTERESTING ITEMS
4. **DETAILS-ON-DEMAND:** SELECT AN ITEM OR GROUP AND GET DETAILS WHEN NEEDED
5. **RELATE:** VIEW RELATIONSHIPS AMONG ITEMS
6. **HISTORY:** KEEP PAST ACTIONS FOR UNDO, REPLAY, AND PROGRESSIVE REFINEMENT
7. **EXTRACT:** ALLOW EXTRACTION OF SUB-COLLECTIONS AND QUERY PARAMETERS.

# ANALYTICAL

## 1. OVERVIEW

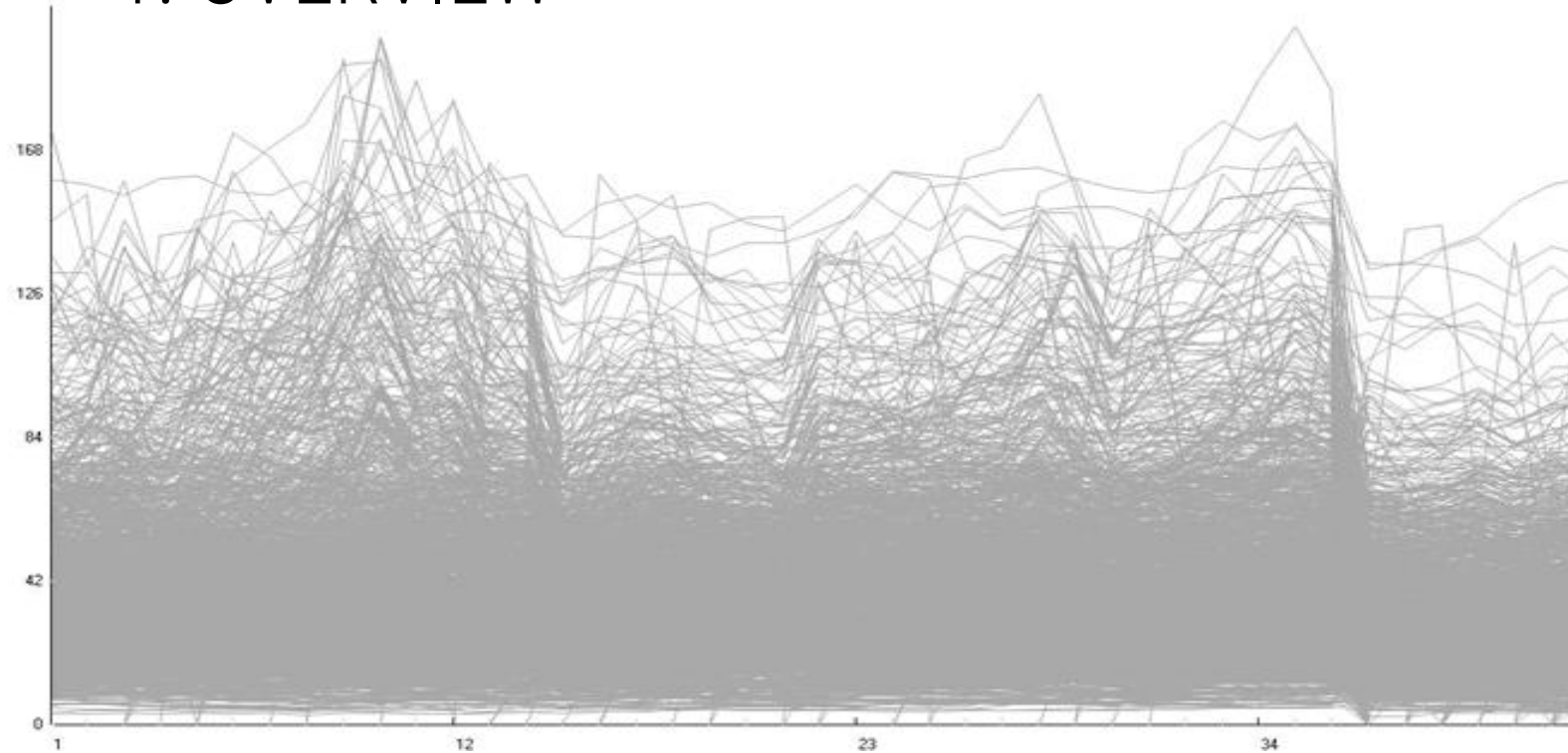

# ANALYTICAL

## 2. ZOOM

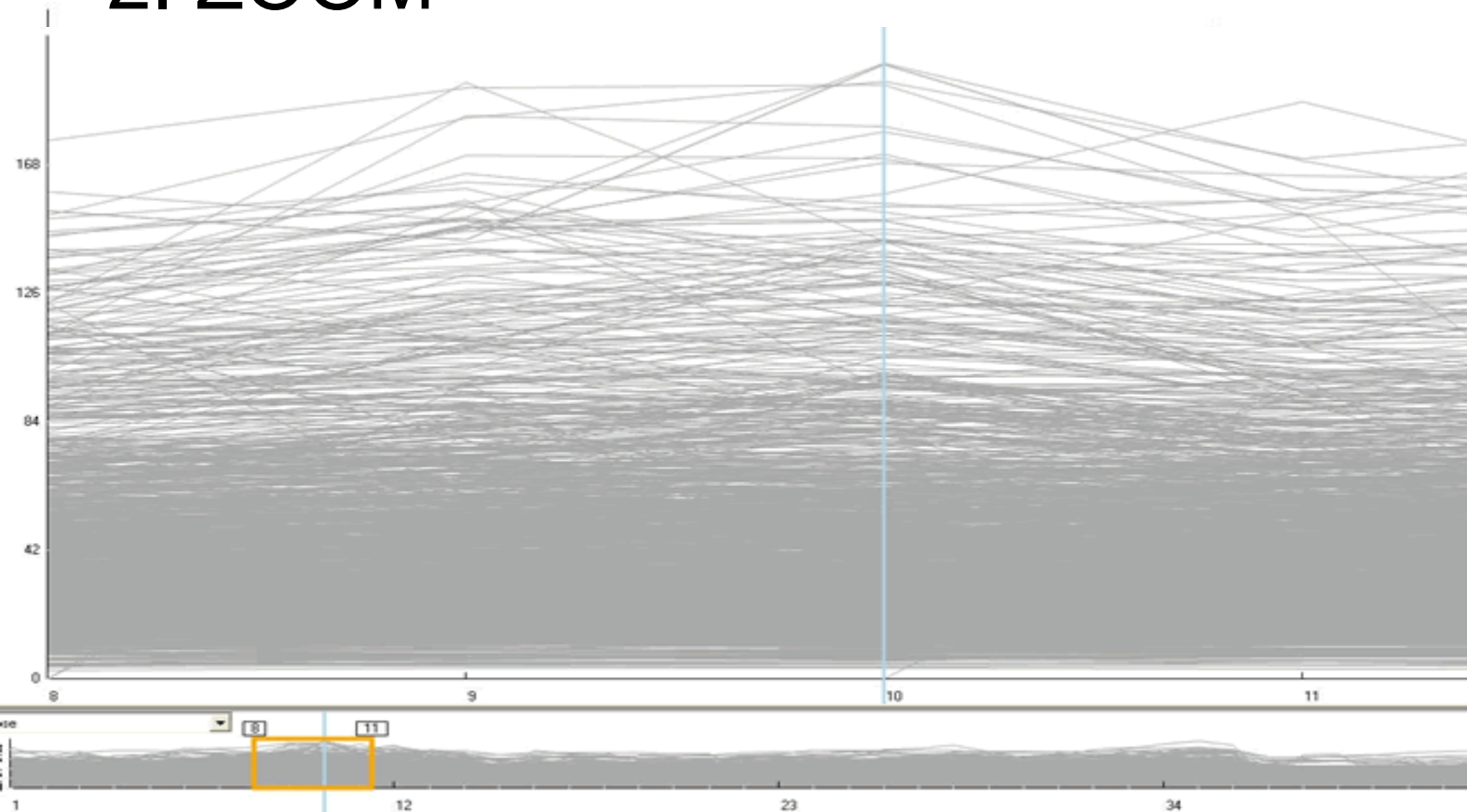

# ANALYTICAL

## 3. FILTER

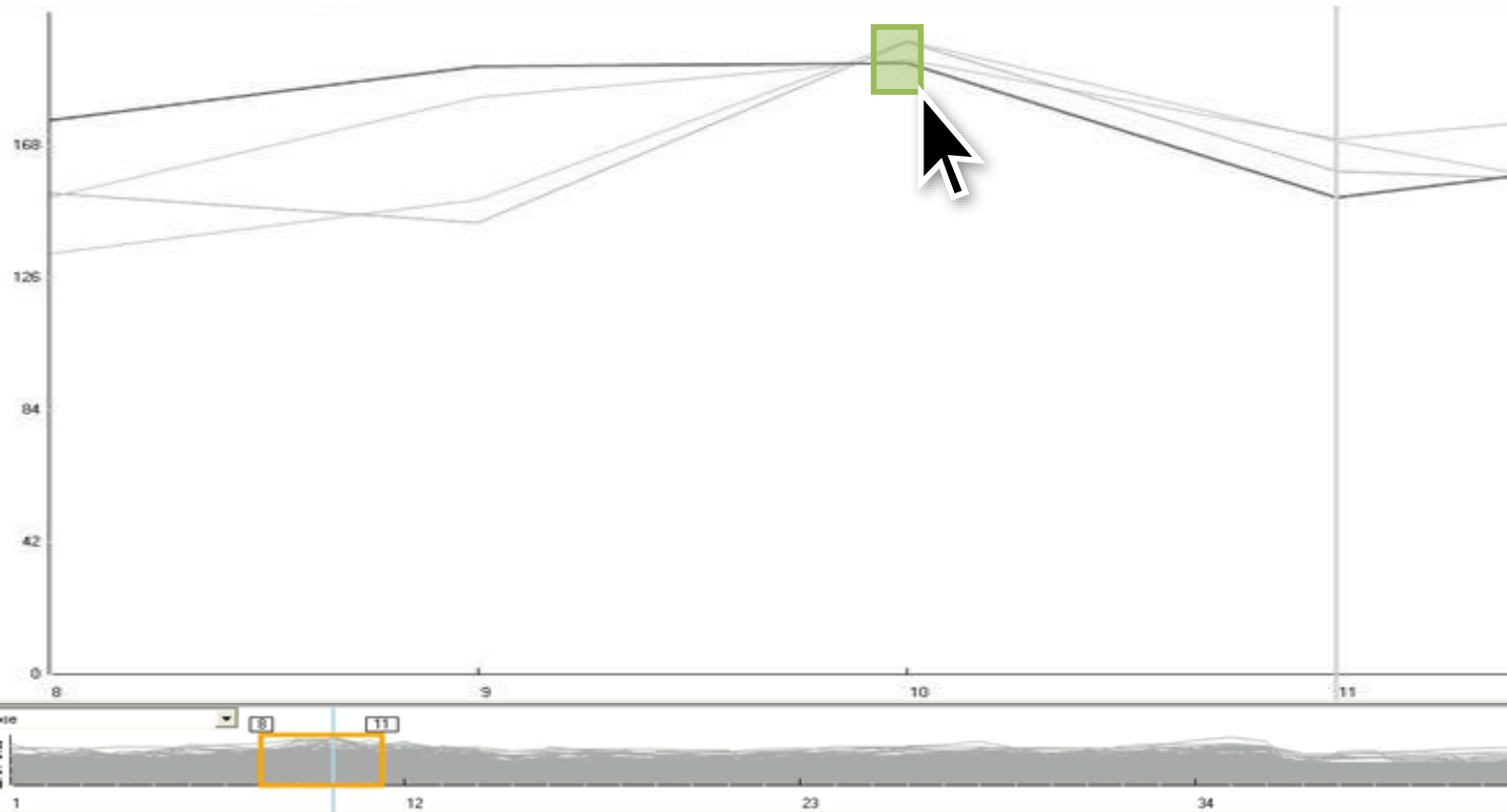

# ANALYTICAL

## 4. DETAILS ON DEMAND

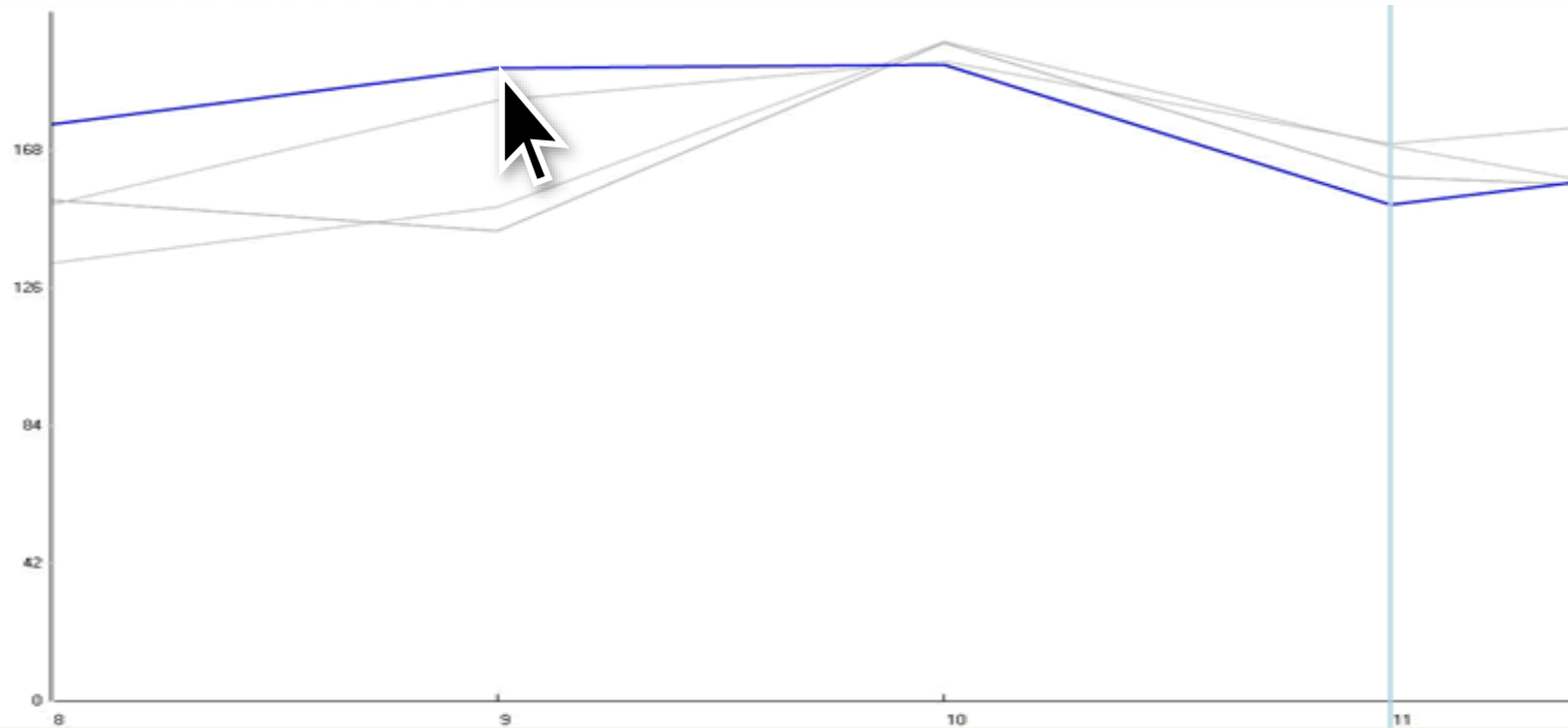

Name [...]	Close
1	74.06
2	86.25
3	102.75
4	100.50
5	143.31
6	160.31
7	168.94
8	175.88
9	193.00
10	194.00
11	151.00
12	167.81
13	112.88
14	126.38
15	89.00
16	119.00
17	145.50
18	139.25
19	132.38
20	122.13
21	104.94
22	140.00
23	150.63
24	161.50
25	159.50
26	133.50
27	130.50
28	149.19
29	138.44
30	108.00
31	102.00
32	99.25
33	111.13
34	139.56
35	131.00
36	123.25

Items | Attribute Statistics |

Name (5/1430)

BRITISH SKY BROADCASTING GP  
PHONE.COM INC  
REPUBLIC NY CORP  
FOUNDRY NETWORKS INC  
CREE INCORPORATED

# VISUAL INFORMATION SEEKING MANTRA

OVERVIEW FIRST, ZOOM AND FILTER, THEN DETAILS ON DEMAND

OVERVIEW FIRST, ZOOM AND FILTER, THEN DETAILS ON DEMAND

OVERVIEW FIRST, ZOOM AND FILTER, THEN DETAILS ON DEMAND

OVERVIEW FIRST, ZOOM AND FILTER, THEN DETAILS ON DEMAND

OVERVIEW FIRST, ZOOM AND FILTER, THEN DETAILS ON DEMAND

OVERVIEW FIRST, ZOOM AND FILTER, THEN DETAILS ON DEMAND

OVERVIEW FIRST, ZOOM AND FILTER, THEN DETAILS ON DEMAND

OVERVIEW FIRST, ZOOM AND FILTER, THEN DETAILS ON DEMAND

OVERVIEW FIRST, ZOOM AND FILTER, THEN DETAILS ON DEMAND

OVERVIEW FIRST, ZOOM AND FILTER, THEN DETAILS ON DEMAND



**INTERACTION AS INTENTS**

# SEVEN CATEGORIES OF INTERACTION BY INTENT

YI ET AL. 2007

SELECT

EXPLORE

FILTER

RECONFIGURE

ENCODE

ABSTRACT/ELABORATE

CONNECT

**SELECT**

MARK SOMETHING AS  
INTERESTING

EXPLORE

FILTER

RECONFIGURE

ENCODE

ABSTRACT/ELABORATE

CONNECT

# BASIC

## Point Selection

Mouse Hover / Click

Touch / Tap

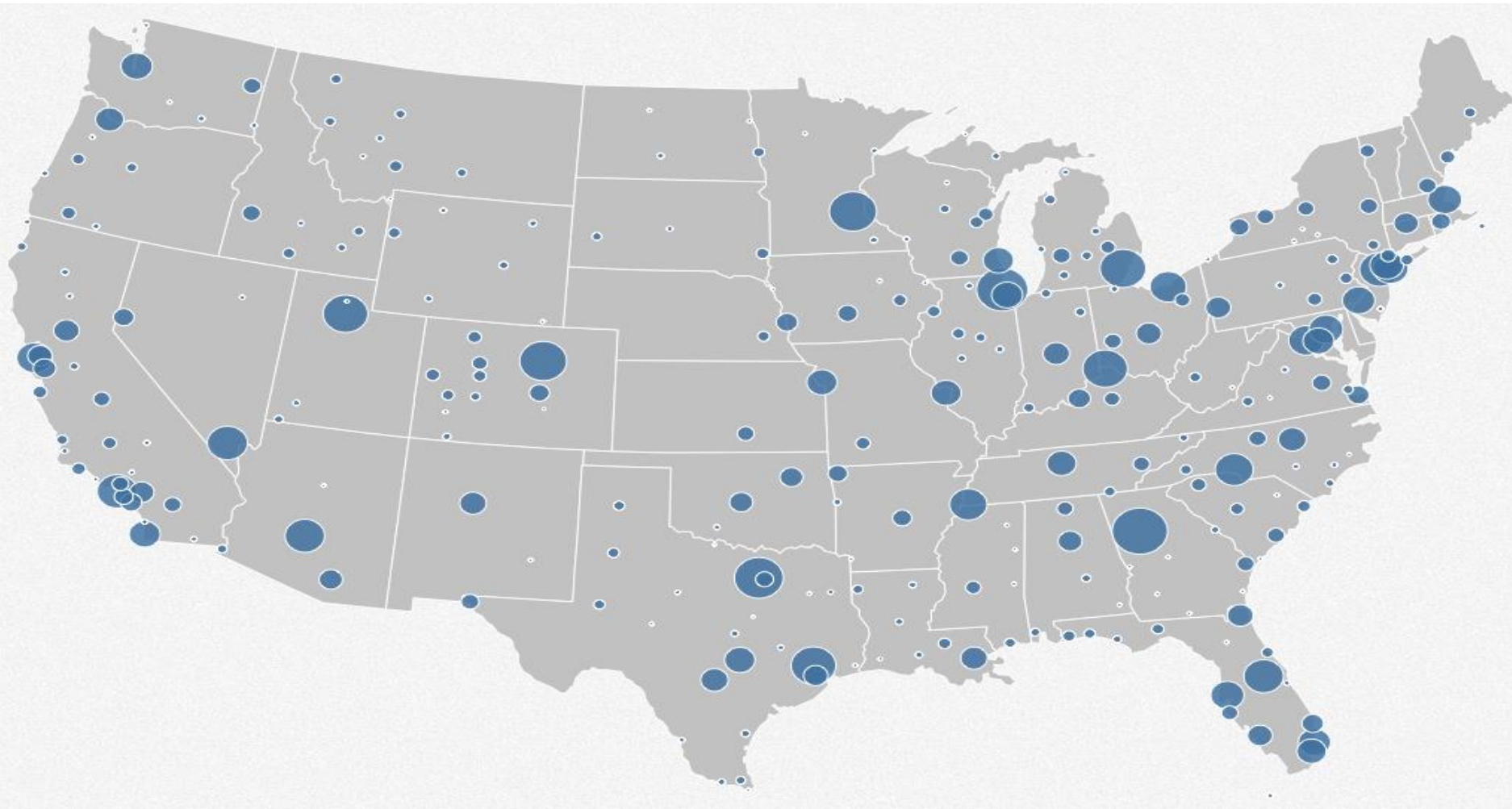

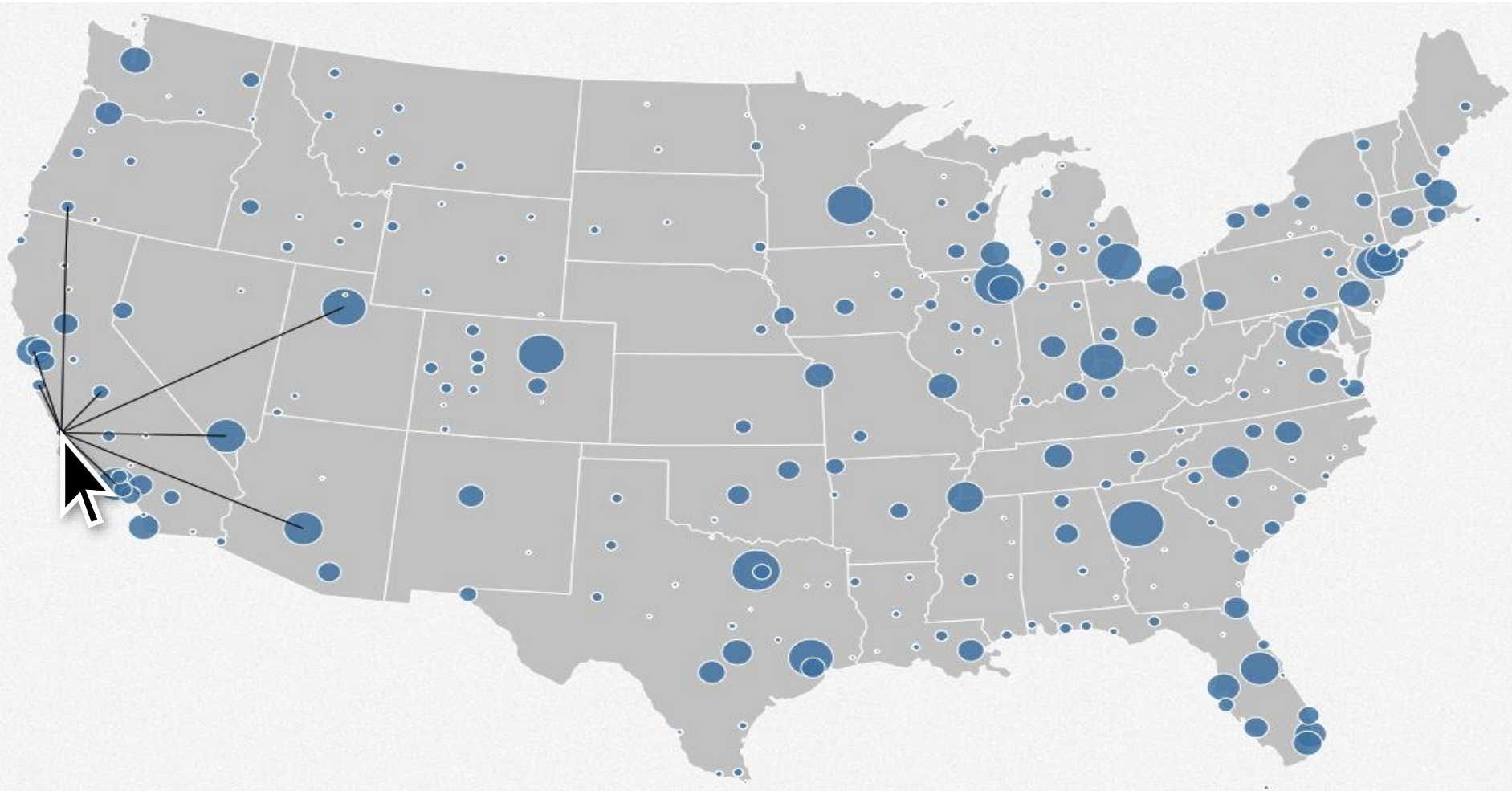

# BASIC

## Point Selection

Mouse Hover / Click

Touch / Tap

Select Nearby Element (e.g., Bubble Cursor)

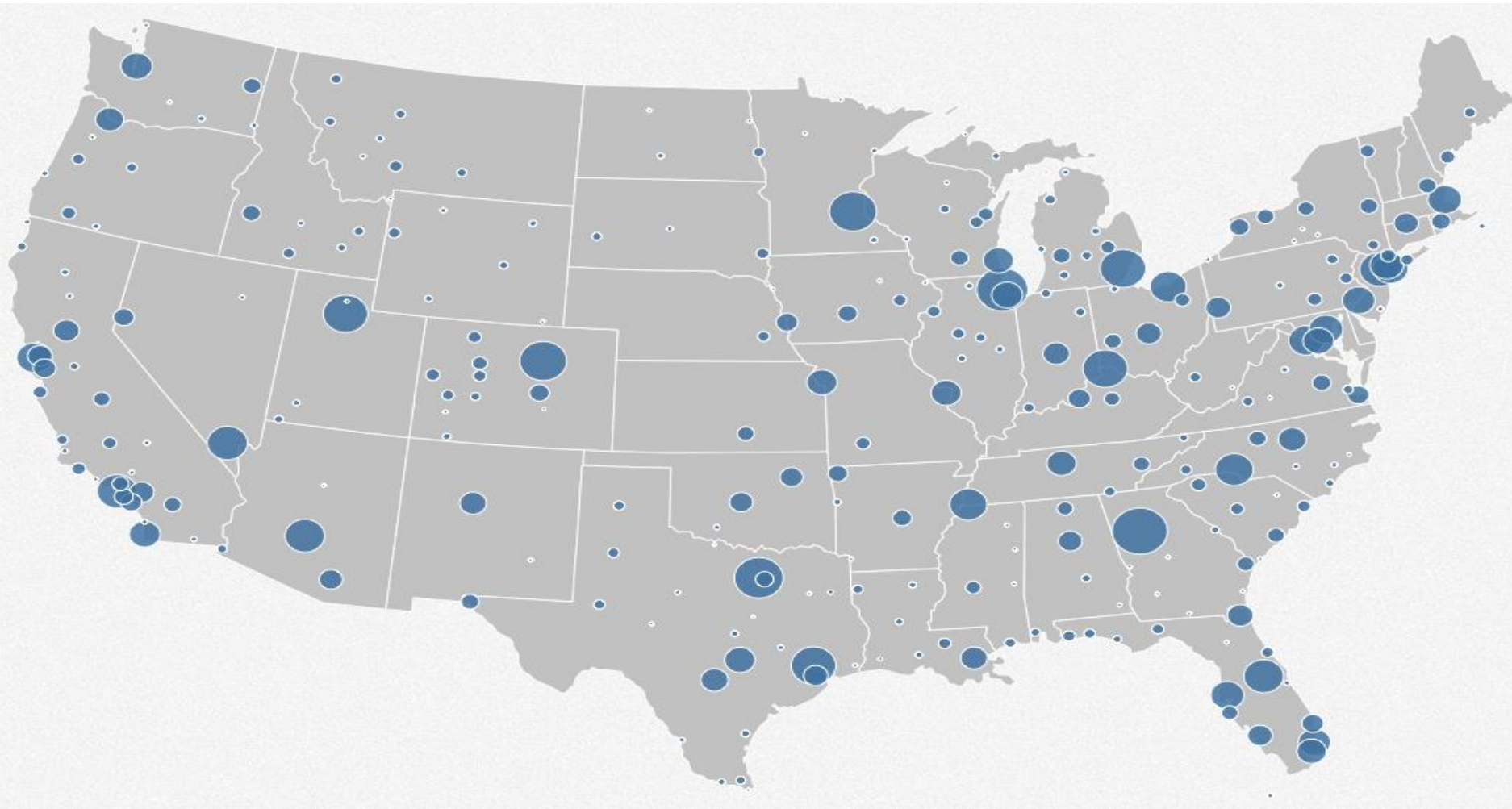



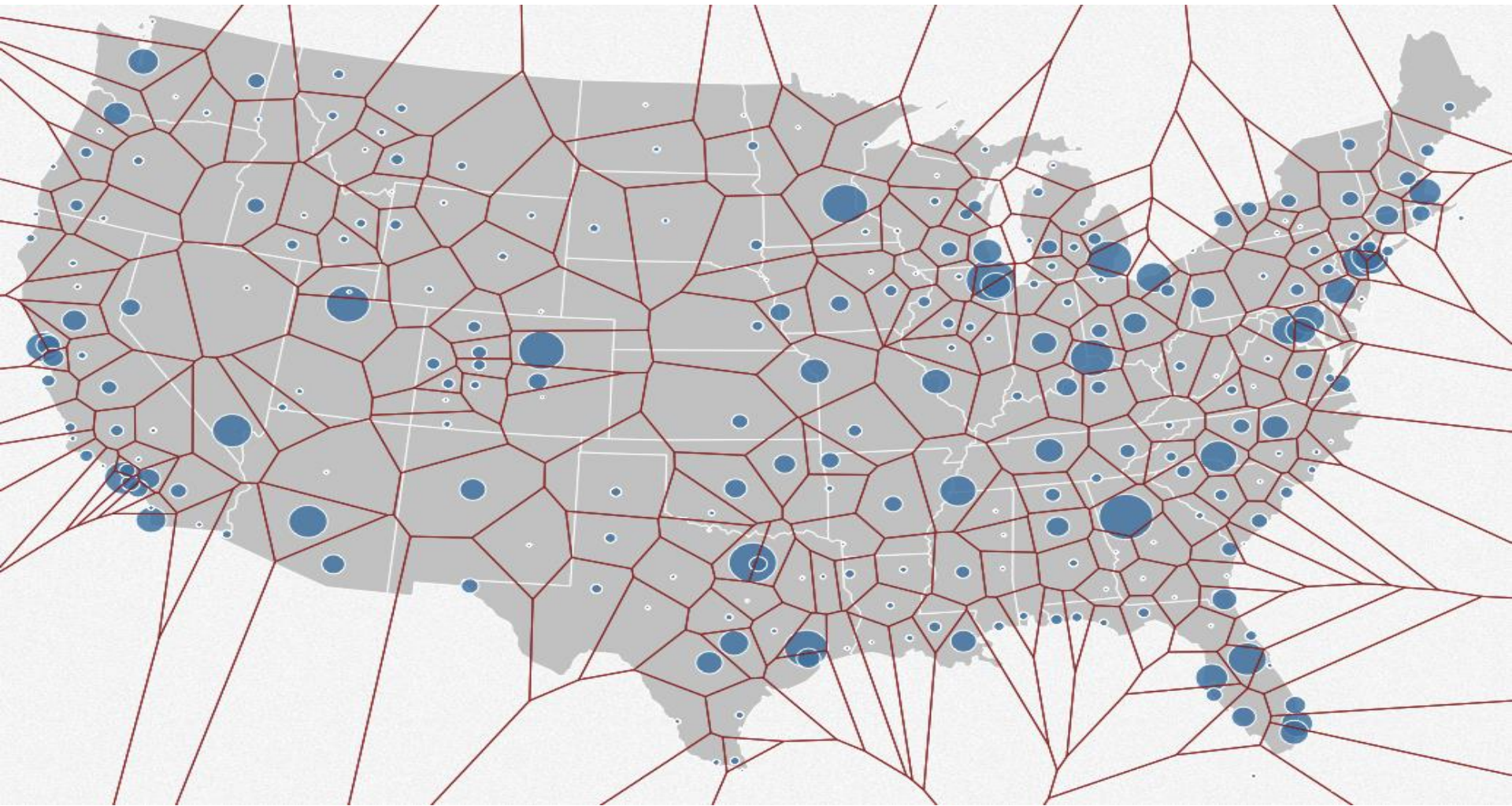

<http://mbostock.github.io/d3/talk/20111018/#28>

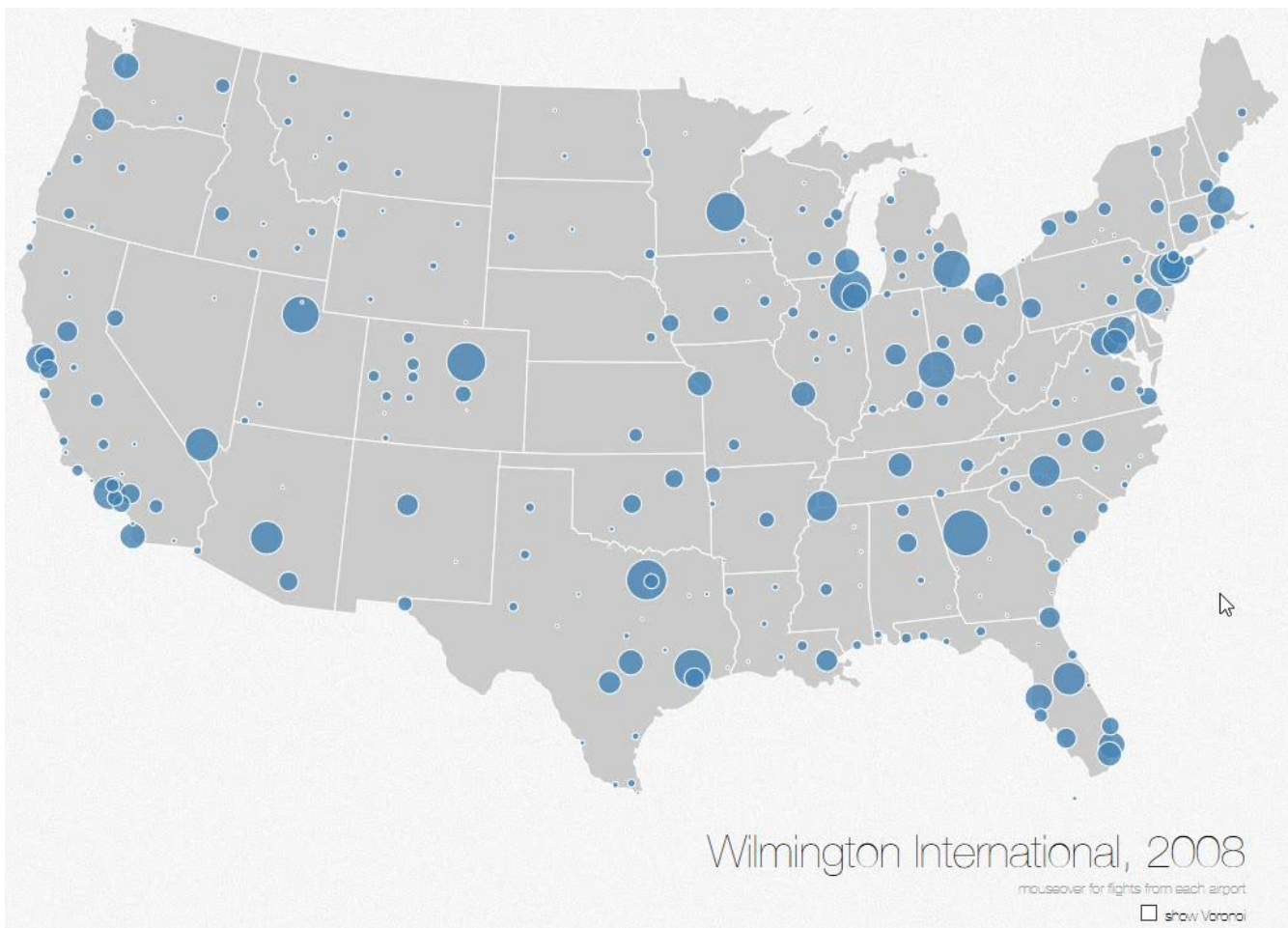

# BASIC

## Point Selection

Mouse Hover / Click

Touch / Tap

Select Nearby Element (e.g., Bubble Cursor)

## Region Selection

Rubber-band or Lasso

Area Cursors (“Brushes”)

# RANGE

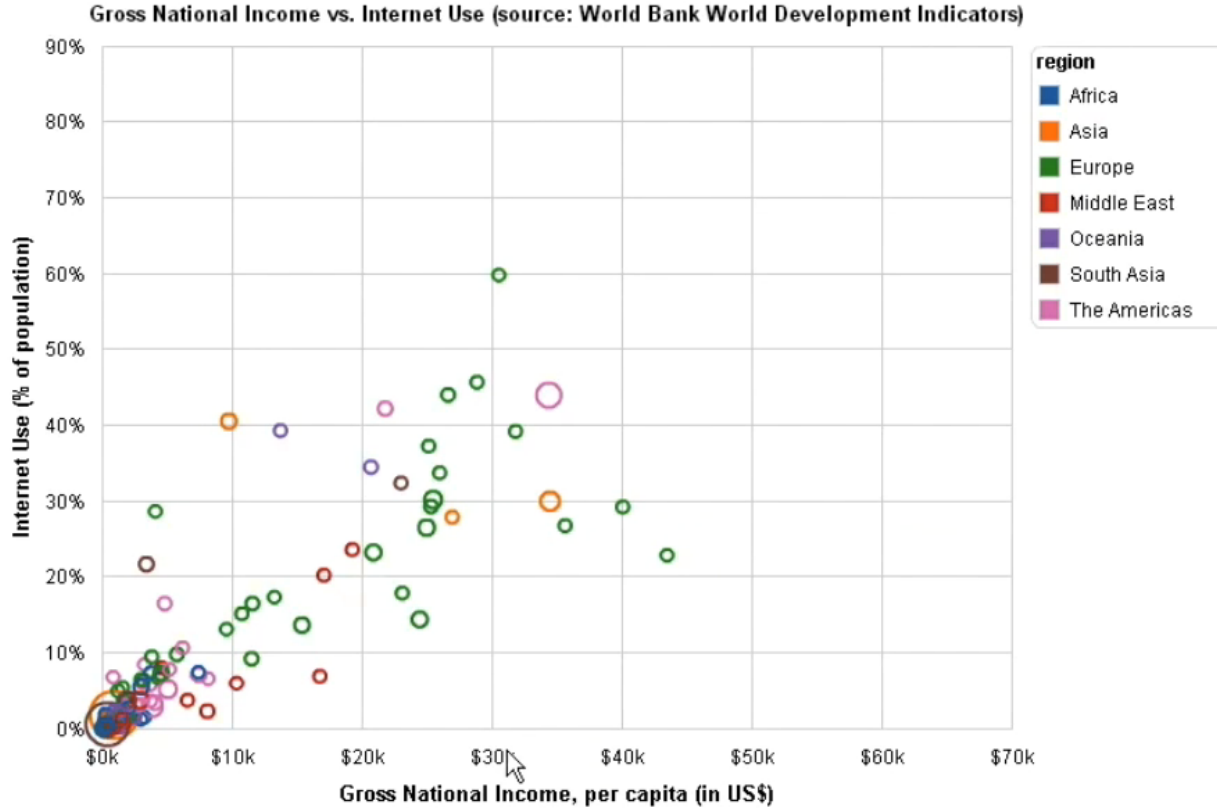

GENERALIZED SELECTION HEER ET AL. 2008

BRUSHES

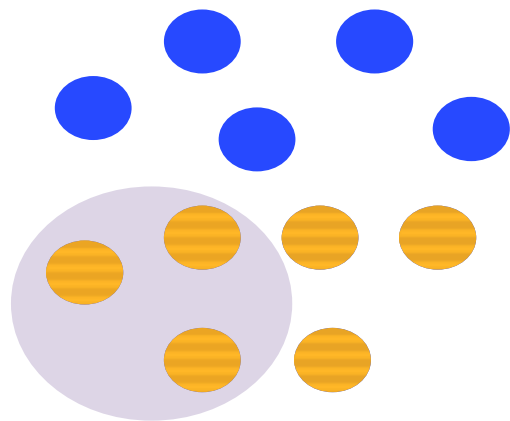

LASSOS

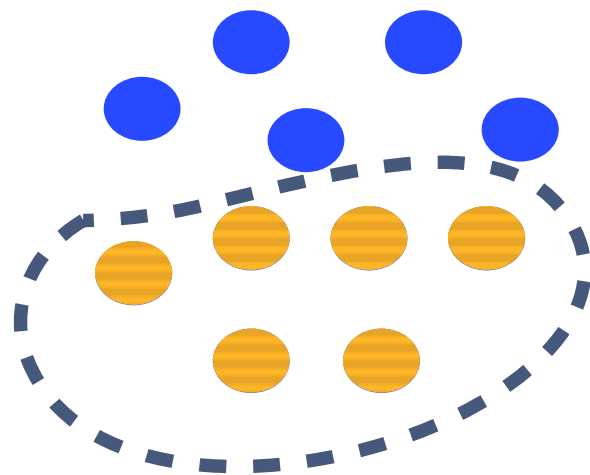

# WILLS' SELECTION TAXONOMY:

# WILLS' SELECTION TAXONOMY

## SELECTION MEMORY

### MEMORY

25 < AGE < 35

COUNTRY =  
CANADA

EDU LEVEL =  
POSTSECONDARY

### MEMORYLESS

25 < AGE < 35

COUNTRY =  
CANADA

EDU LEVEL =  
POSTSECONDARY

# SELECTION OPERATIONS

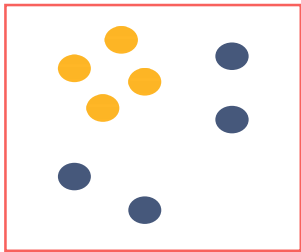
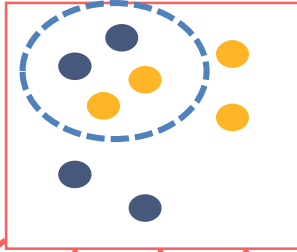

REPLACE

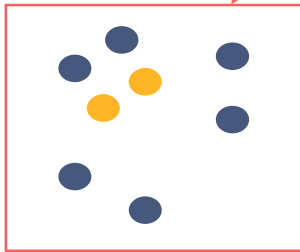

INTERSECT

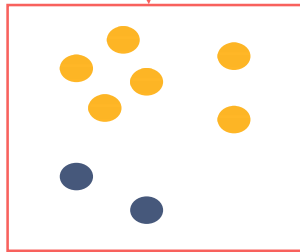

ADD

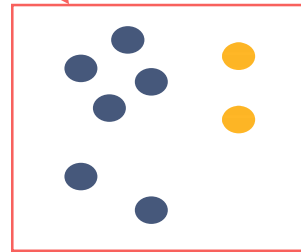

SUBTRACT

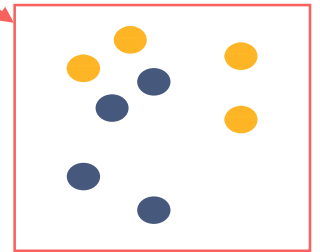

TOGGLE



# RECOMMENDED SELECTION OPERATIONS

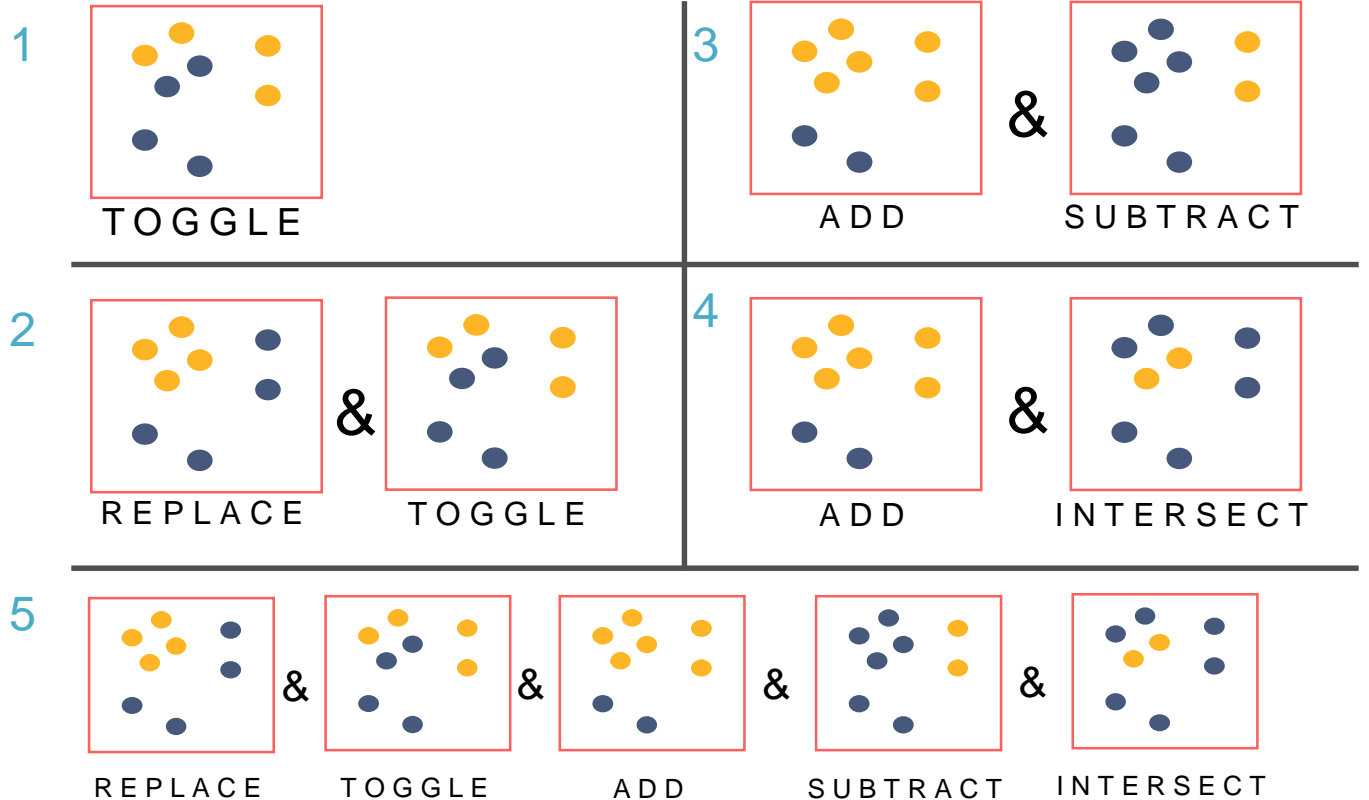

# HIGHLIGHTING

SELECTION + CHANGE IN APPEARANCE

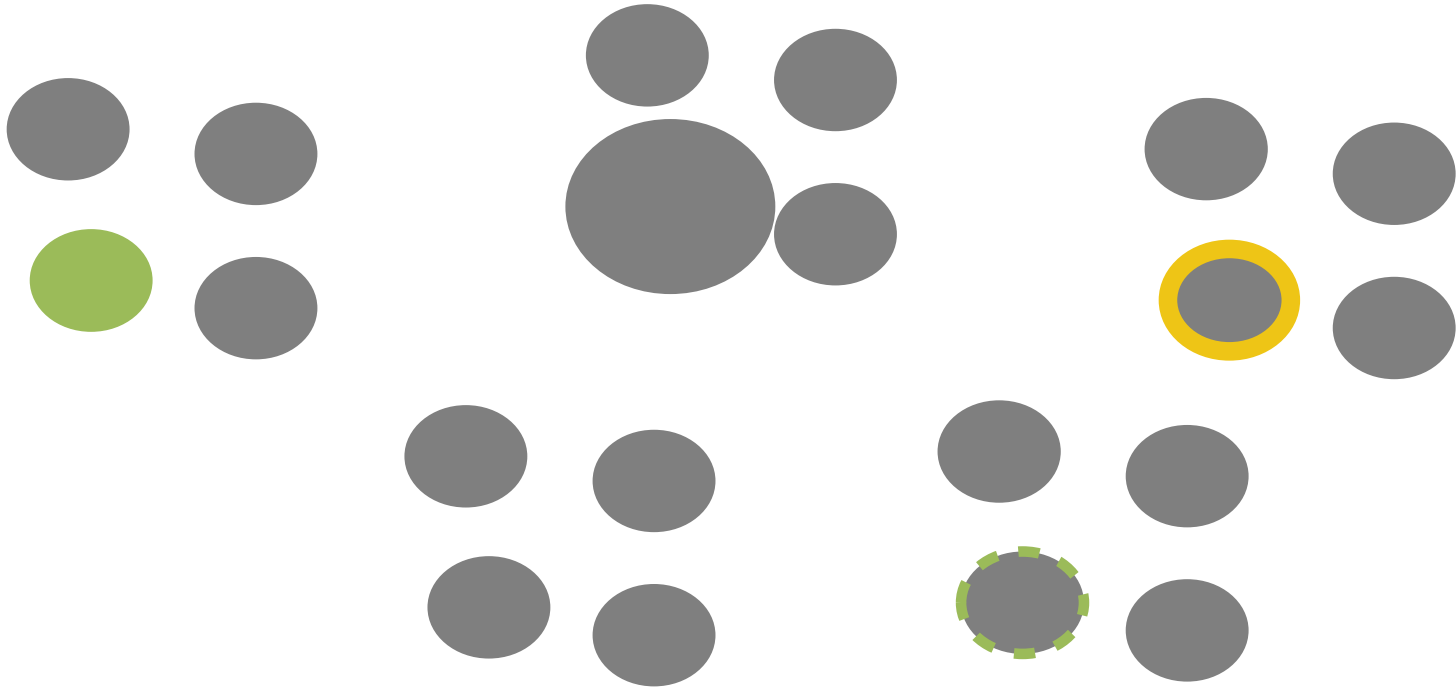

SELECT

EXPLORE

SHOW ME SOMETHING  
ELSE

FILTER

RECONFIGURE

ENCODE

ABSTRACT/ELABORATE

CONNECT

# PROBLEM

Where am I?



# NAVIGATION

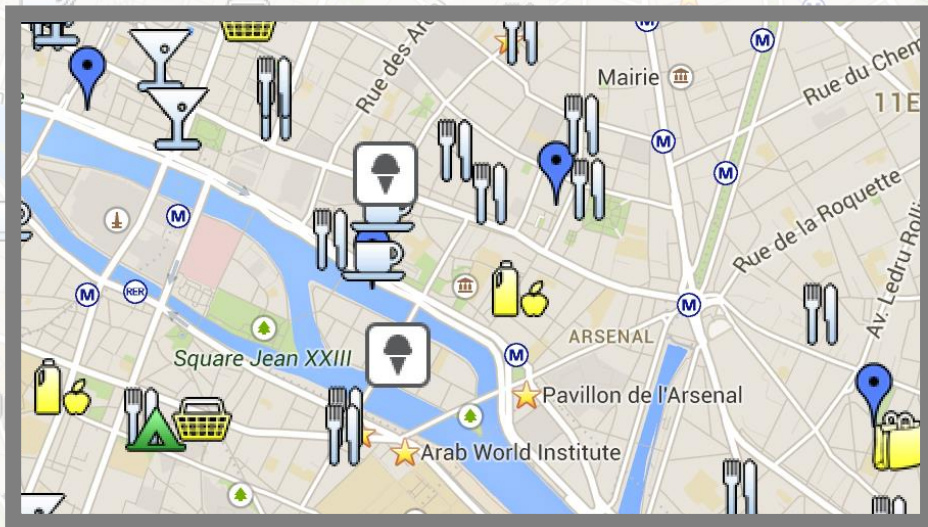

**PANNING**



**ZOOMING**



# NAVIGATION



**PANNING**



**ZOOMING**



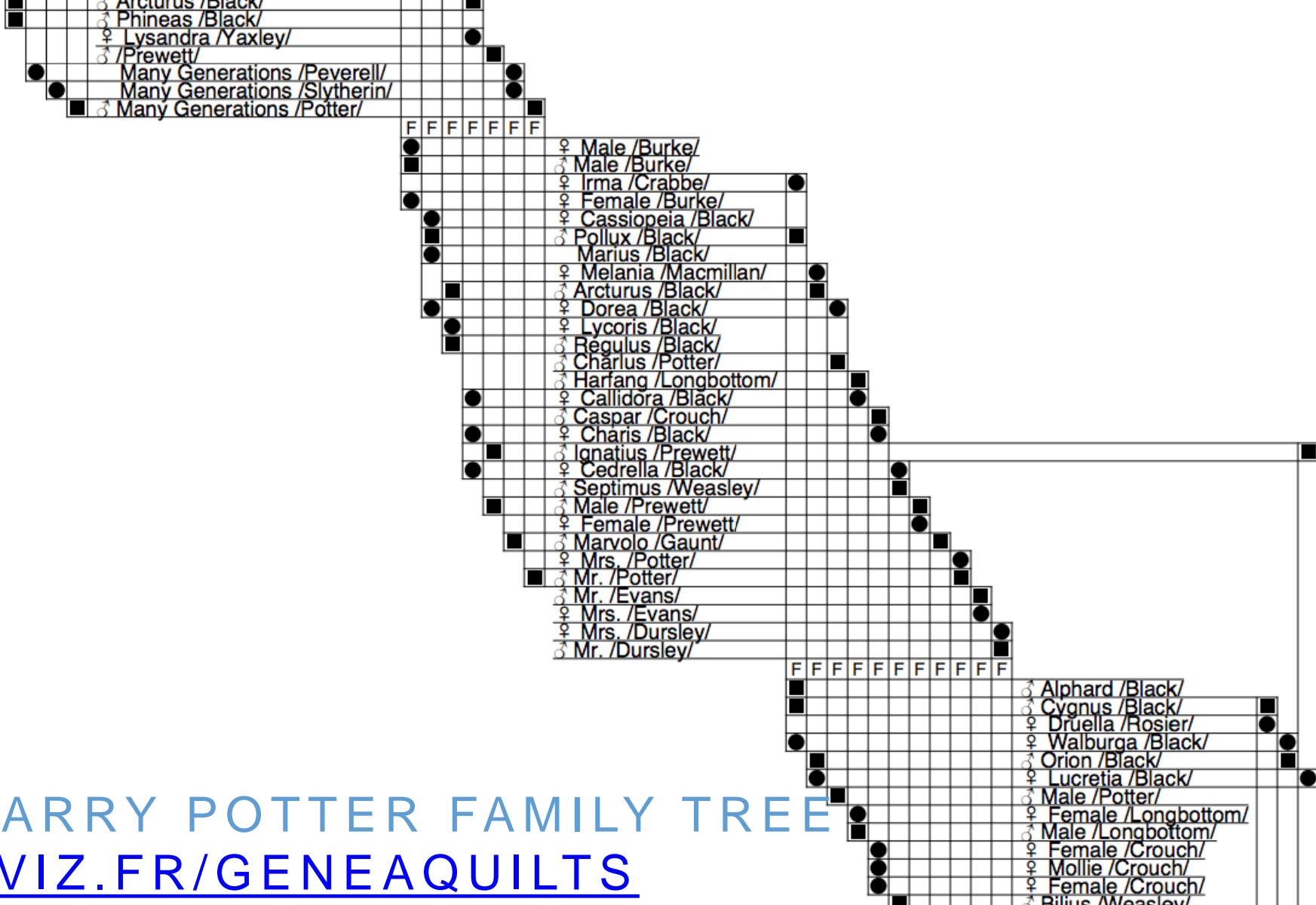

HARRY POTTER FAMILY TREE

[AVIZ.FR/GENEAQUILTS](http://AVIZ.FR/GENEAQUILTS)

SELECT

EXPLORE

**FILTER**

SHOW ME SOMETHING  
CONDITIONALLY

RECONFIGURE

ENCODE

ABSTRACT/ELABORATE

CONNECT



# FILTERING

```
> SELECT house-address  
FROM realty-db  
WHERE price >= 200,000  
price <= 400,000 AND  
bathrooms > 1  
garage == 2  
bedrooms >= 3
```

## REPLACING A QUERY WITH "DYNAMIC QUERY WIDGETS"

Dynamic Browser : DC Home Finder

ID Number	Duelling Address	City
1		
1		
1		
1		

The yellow dots above are homes in the DC area for sale. You may get more information on a home by selecting it. You may drag the 'A' and 'B' distance markers to your office or any other location you want to live near. Select distances, bedrooms, and cost ranges by dragging the corresponding slider boxes on the right. Select specific home types and services by pressing the labeled buttons on the right.

Dynamic Browser  
Reset  
Save  
Dist to A:  
1 19 30  
Dist to B:  
1 6 30  
Bedrooms:  
1 2 4 7  
Cost:  
\$50k 16 \$500k 38  
Look at:  
Hse TH Cnd  
Features:  
Grg Fp1  
CAC New

HOMEFINDER WILLIAMSON AND SCHNEIDERMAN 1992

**Dynamic Queries Demos:  
Revised Homefinder  
and Text Version  
plus Health Statistics Atlas**

**Ben Shneiderman**

**COPYRIGHT © 1994 UNIVERSITY OF MARYLAND**

# DIRECT MANIPULATION

1. Visual representation of objects and actions
2. Rapid, incremental and reversible actions
3. Selection by pointing (not typing)
4. Immediate and continuous display of results

**Dynamic Queries Demos:  
Revised HomeFinder  
and Text Version  
plus Health Statistics Atlas**

**Ben Shneiderman**

**COPYRIGHT © 1994 UNIVERSITY OF MARYLAND**

# CRIMESPOTTING



Report data last published by Oakland Police: 314 days ago

Home

Map

Crime Reports

Police Beats

Alerts

API

About

Feedback

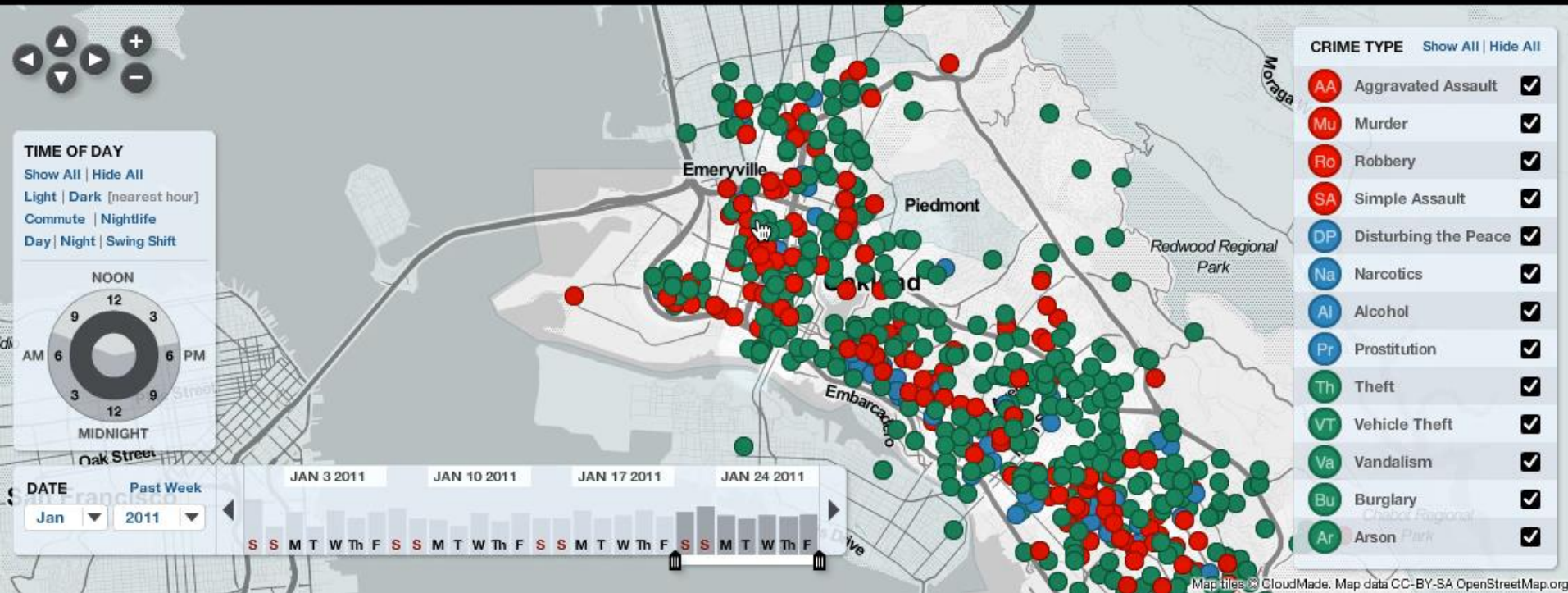

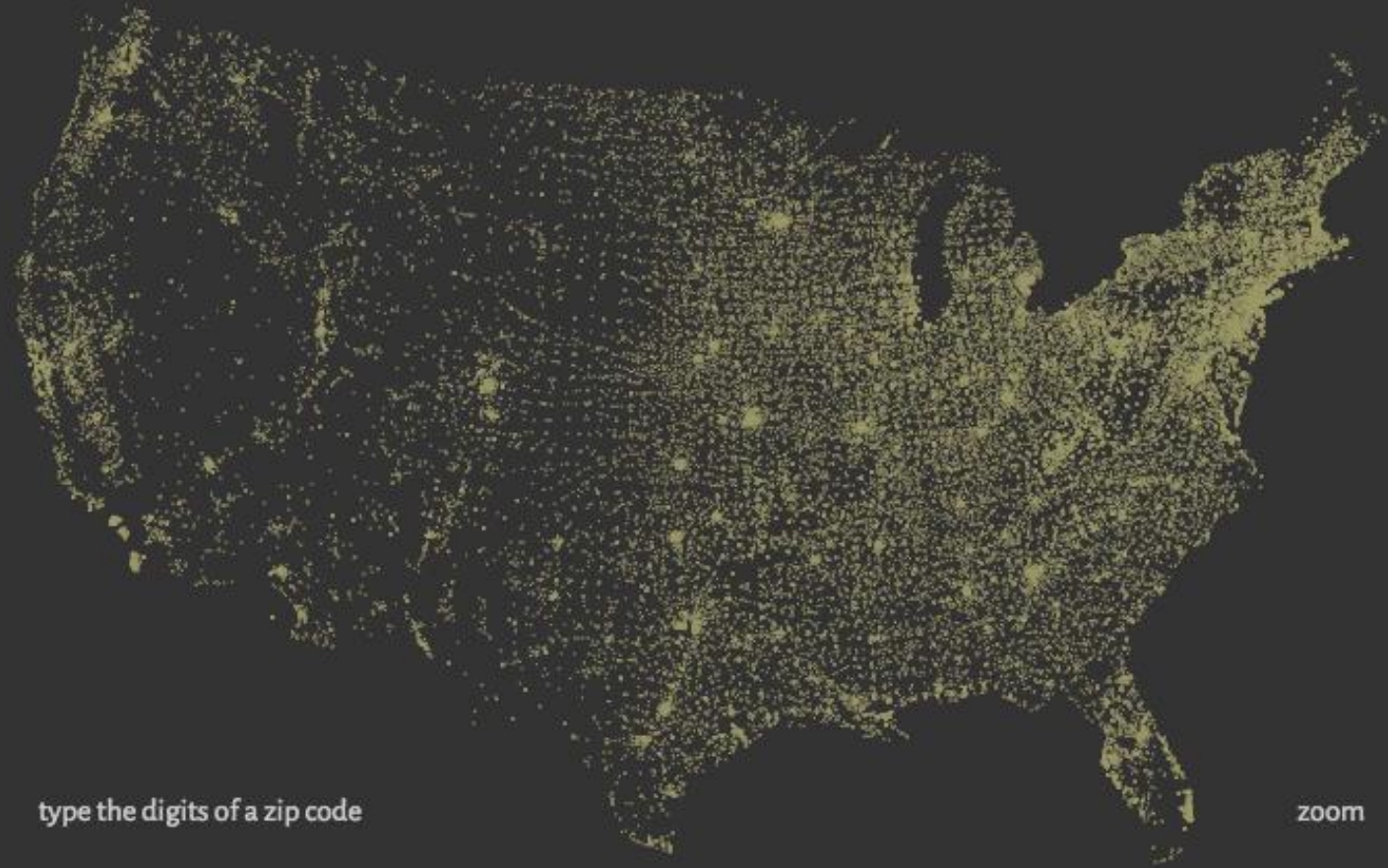

type the digits of a zip code

zoom

Hit the letter **z**, or click the word **zoom** to enable or disable zooming.

Baby Name >

Both  Boys  Girls

Current rank: boys 

1000	500	100	25	1
------	-----	-----	----	---

  
girls 

1000	500	100	25	1
------	-----	-----	----	---

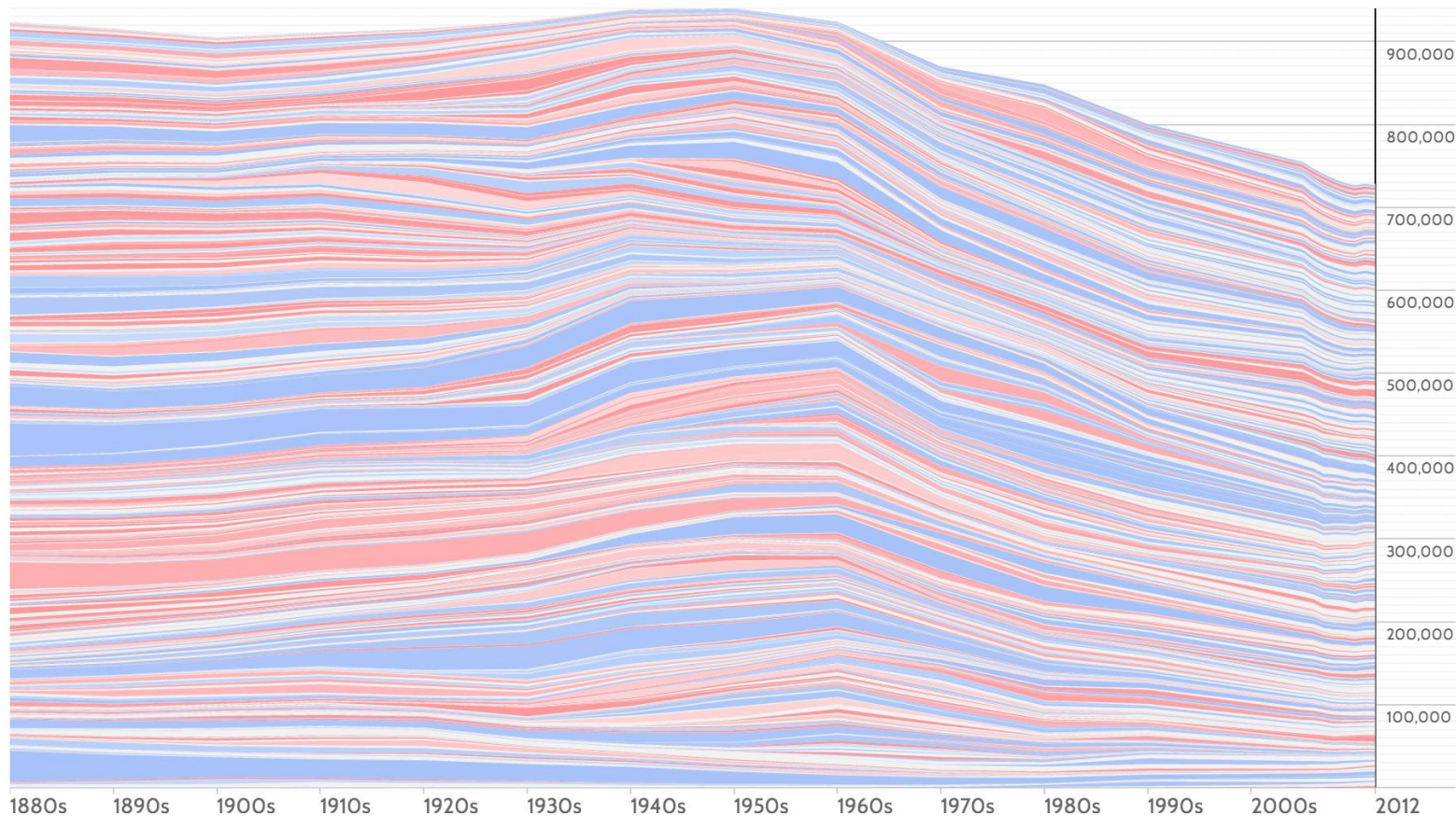

BABY NAME VOYAGER MARTIN WATTENBERG 2005

SELECT

EXPLORE

FILTER

SHOW ME A DIFFERENT  
ARRANGEMENT

**RECONFIGURE**

ENCODE

ABSTRACT/ELABORATE

CONNECT



# RE-ARRANGING DATA

## Fruit Sales 1992-1997

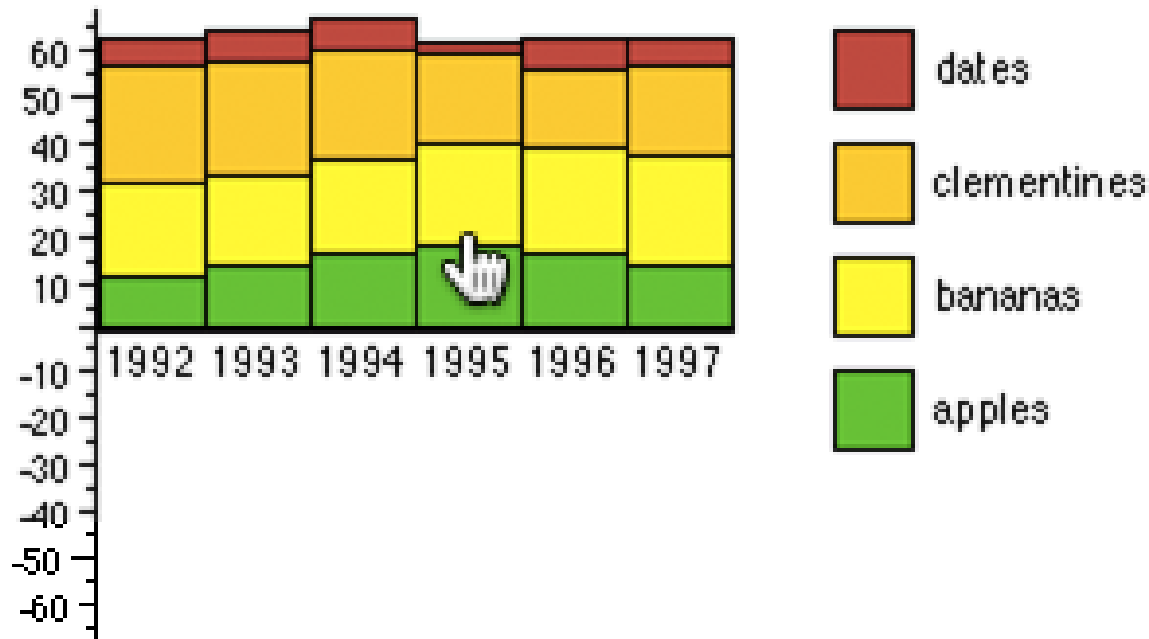

INTERACTIVE STACKED HISTOGRAMS [DIX & ELLIS, 1998]

## Graph Viewer

Roll-up by:

All

Visualization:

Matrix

Sort by:

None

Edge centrality threshold:

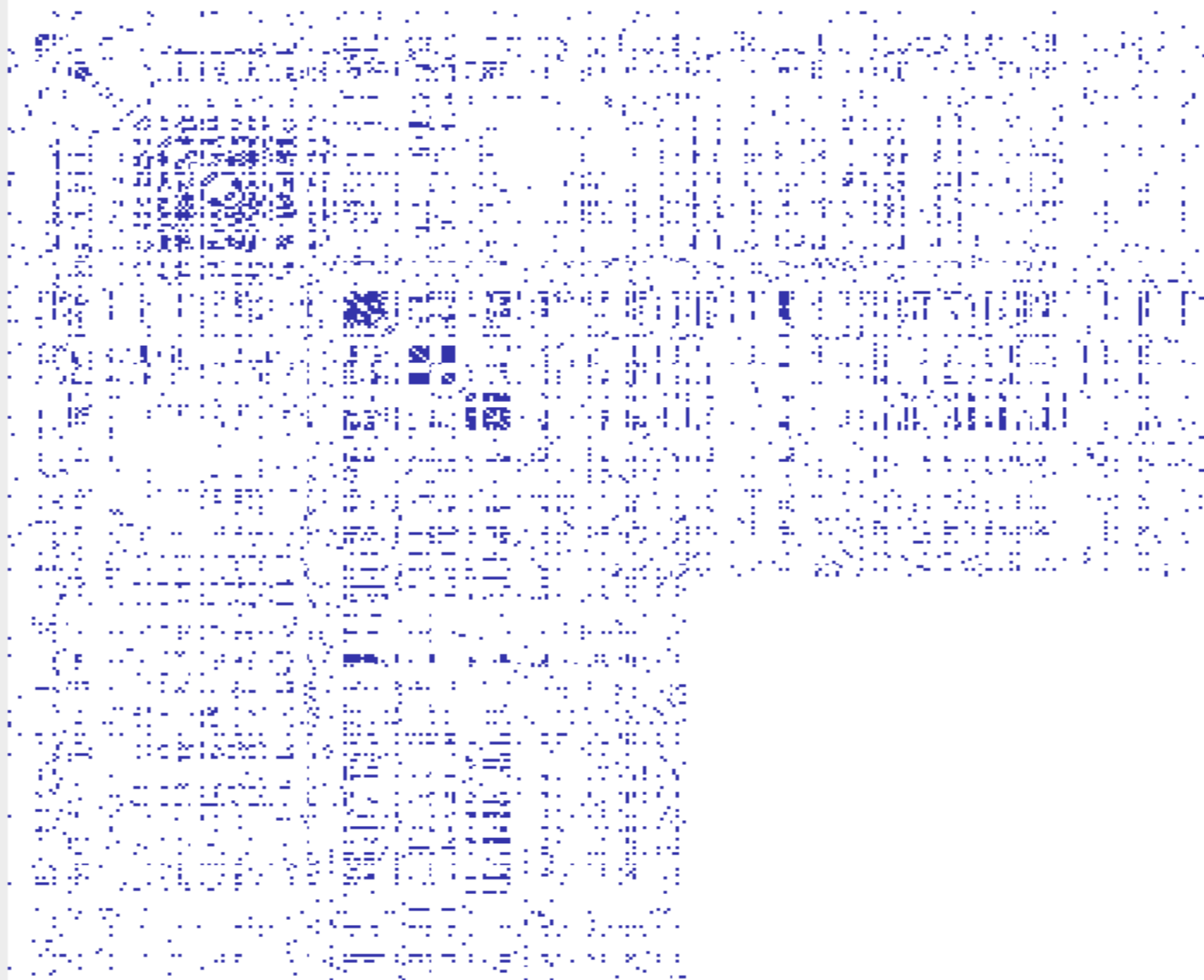
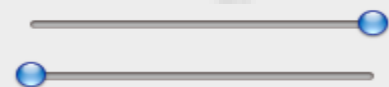

## Graph Viewer

Roll-up by:

All

Visualization:

Matrix

Sort by:

Linkage

Edge centrality filters:

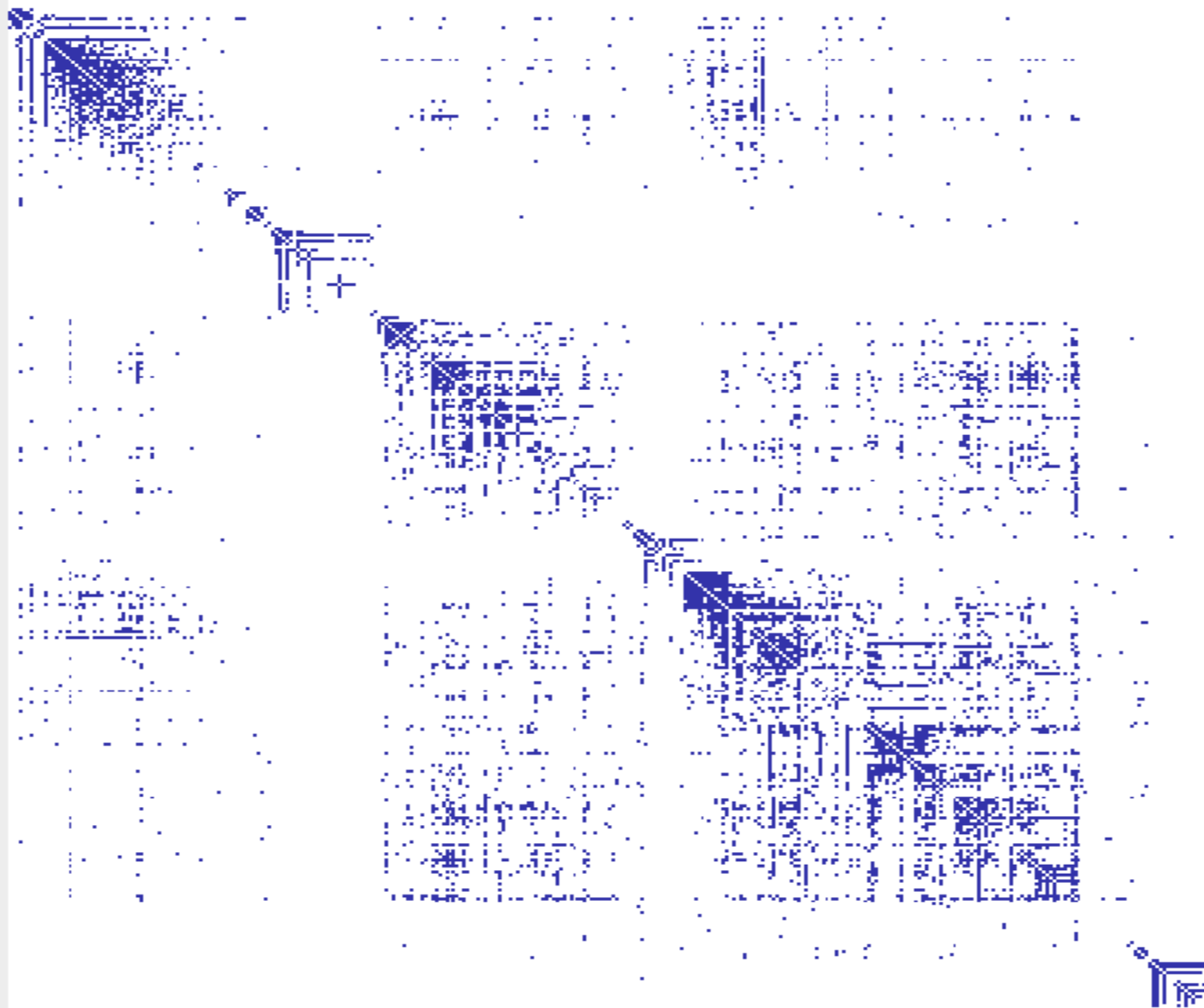
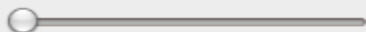
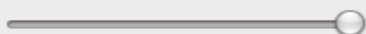

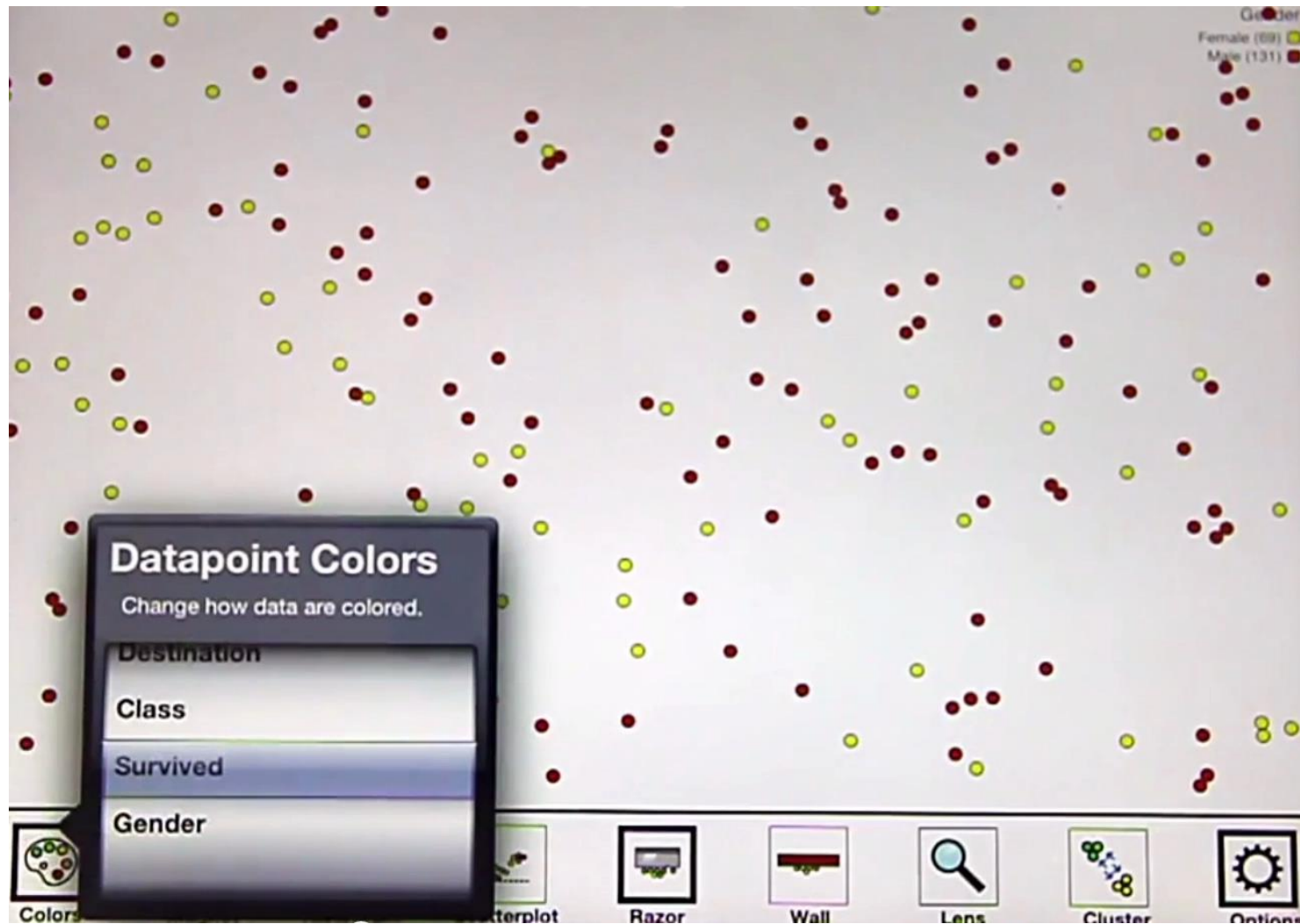

**KINETICA [RZSZORTARKSI & KITTUR 2013]**

SELECT

EXPLORE

FILTER

RECONFIGURE

**ENCODE**

SHOW ME A DIFFERENT  
REPRESENTATION

ABSTRACT/ELABORATE

CONNECT

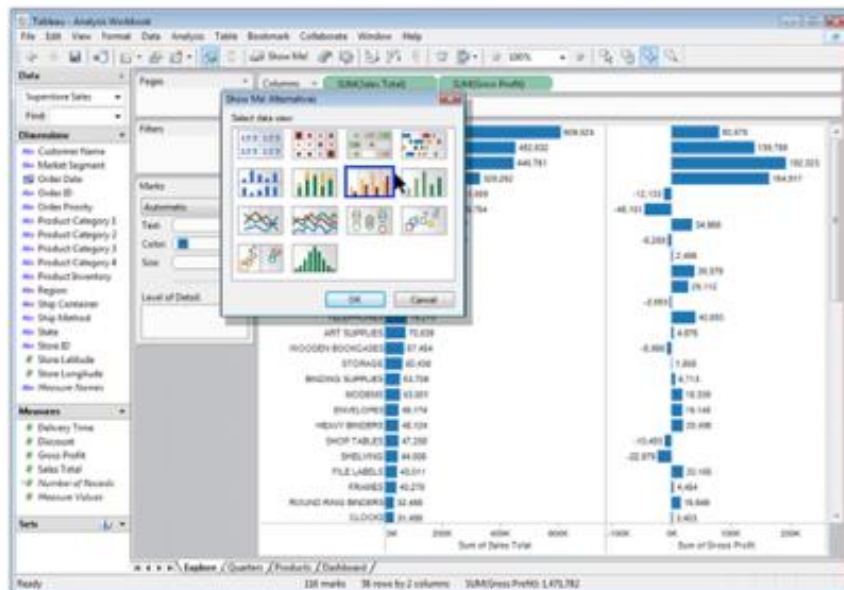
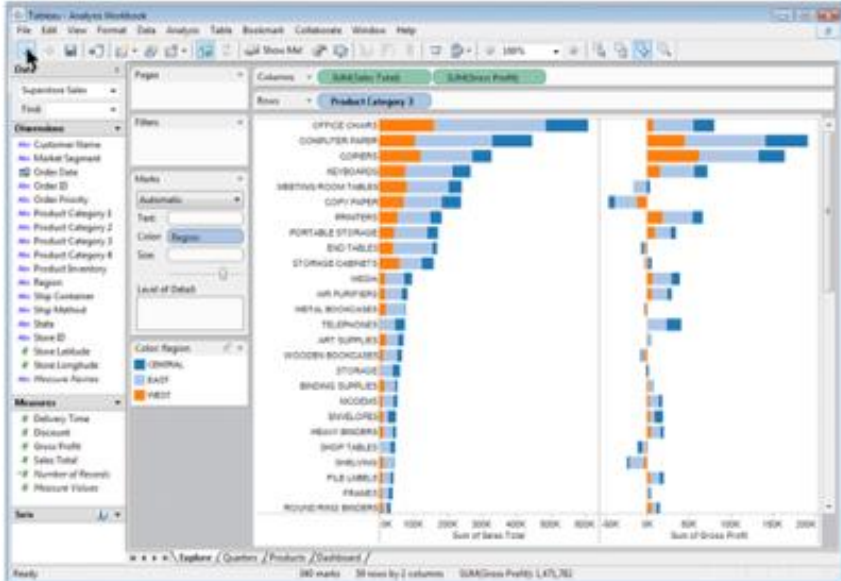
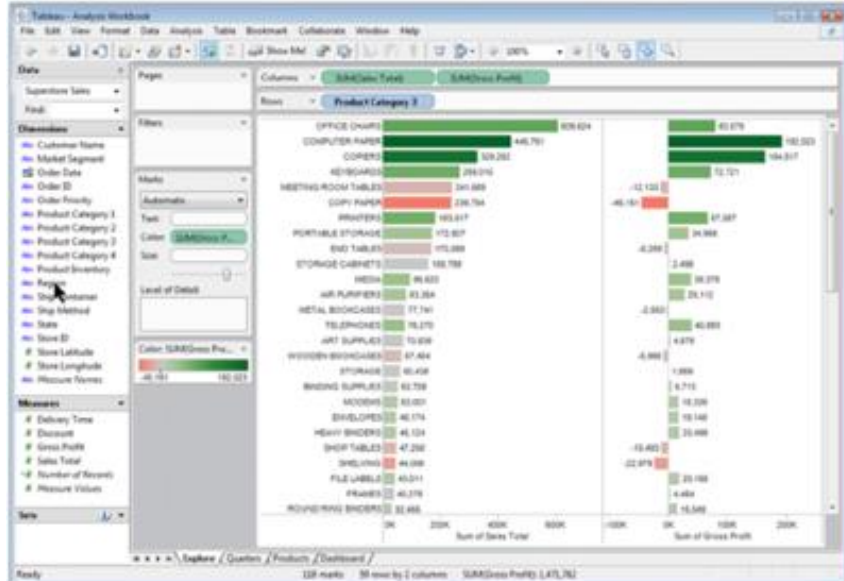

SELECT  
EXPLORE  
FILTER  
RECONFIGURE  
ENCODE

SHOW ME MORE  
OR LESS DETAIL

ABSTRACT/ELABORATE

CONNECT

# CHANGING LEVELS OF



POWERS OF TEN RAY & CHARLES EAMES 1977





**POWERS  
OF TEN**

# SEMANTIC ZOOMING

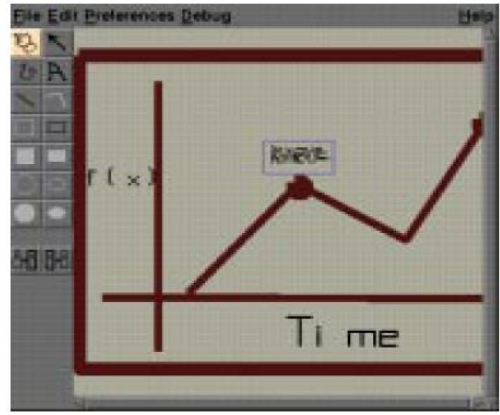
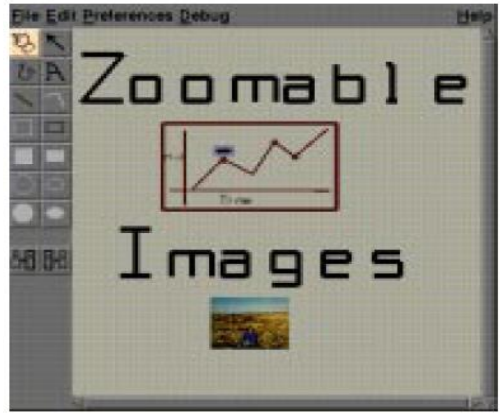
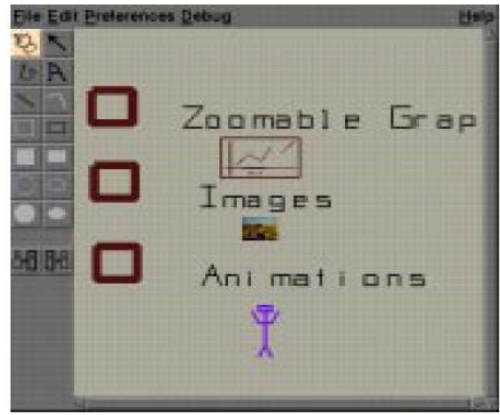
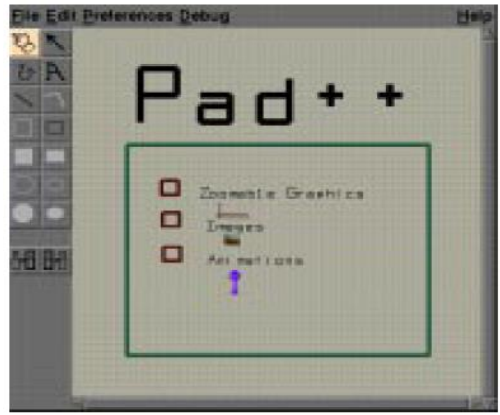
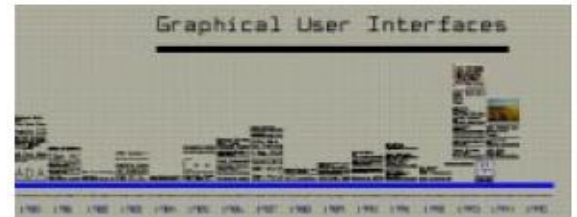
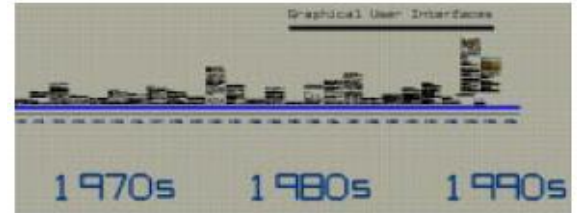

PAD++ BEDERSON AND HOLLAN 1994

# LiveRAC

ENCODINGS CHANGE

–COLORED BOX

–SPARKLINE

–SIMPLE LINE CHART

–FULL CHART: AXES  
AND TICKMARKS

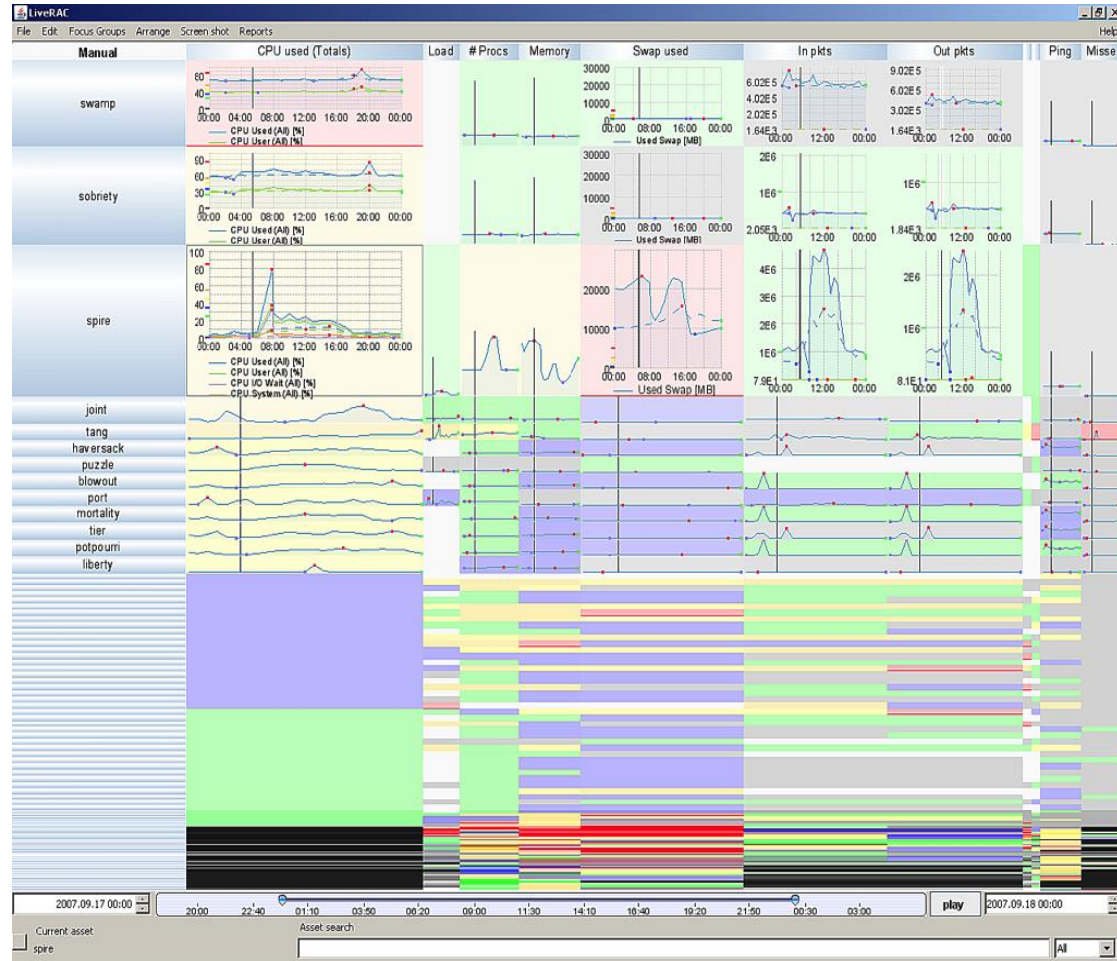

MCLACHLAN ET AL. 2008

# OVERVIEW + DETAIL

## Panning a large graph

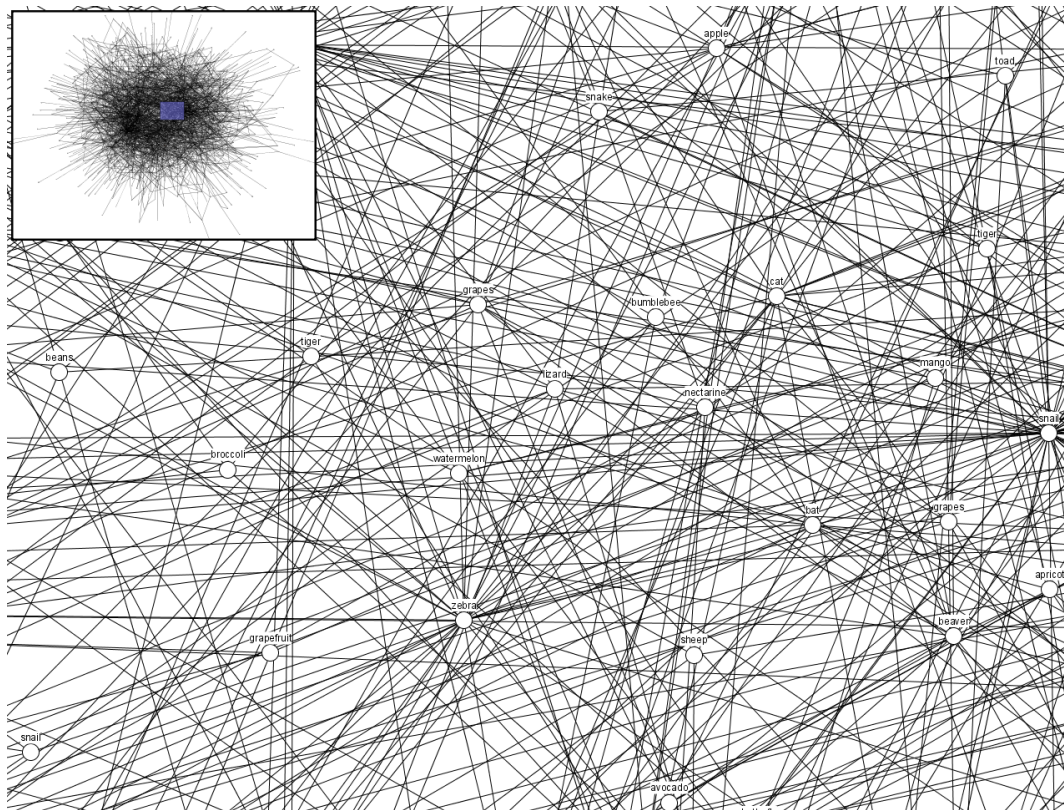

# OVERVIEW +

## Panning a line chart

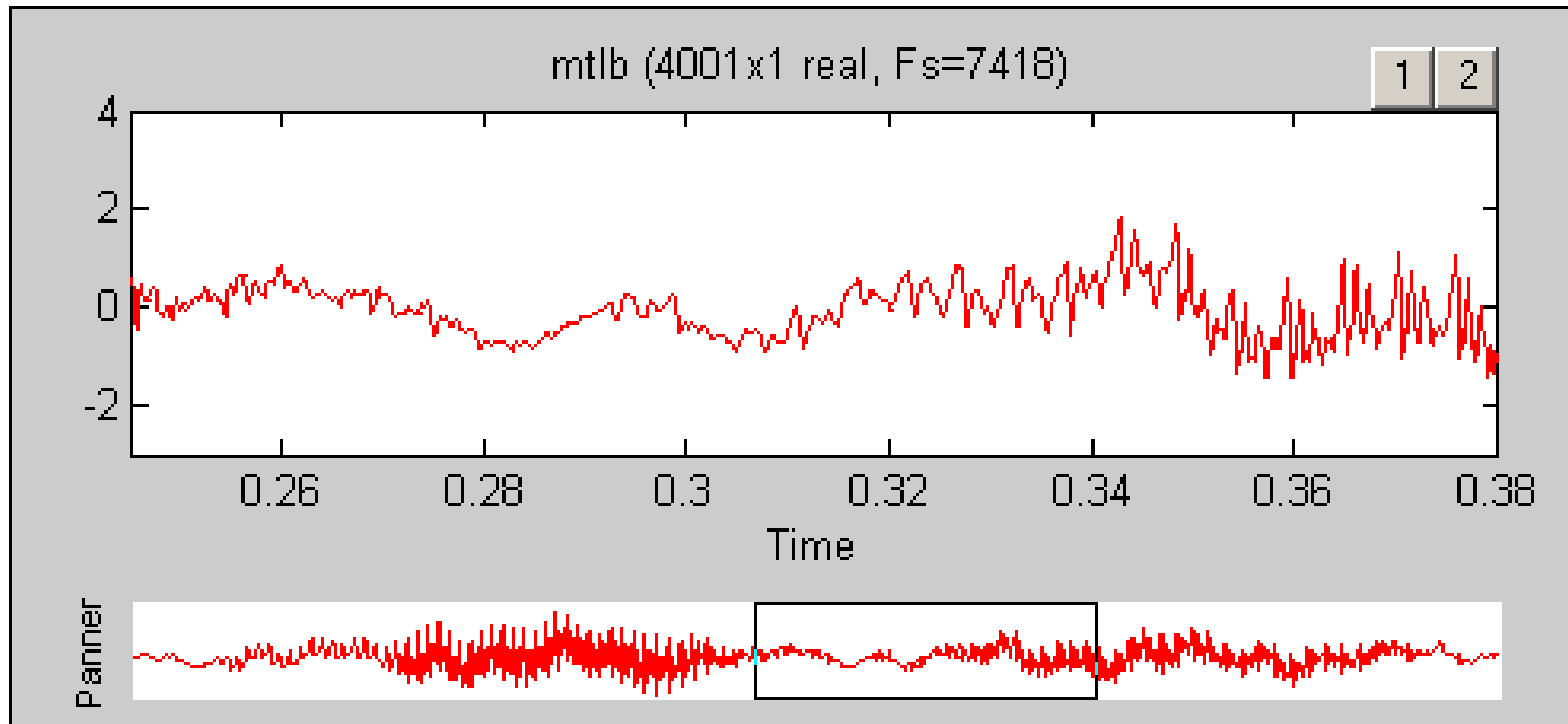

# OVERVIEW + DETAIL

## Browsing Multiple Views

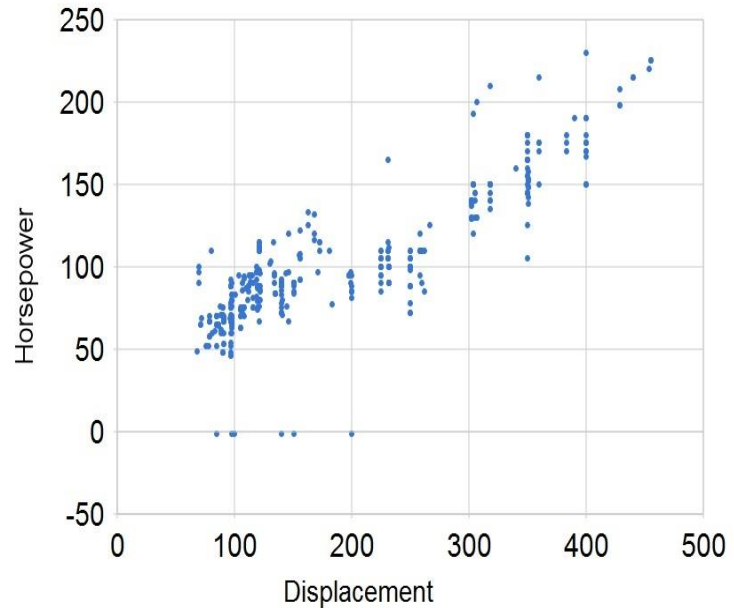
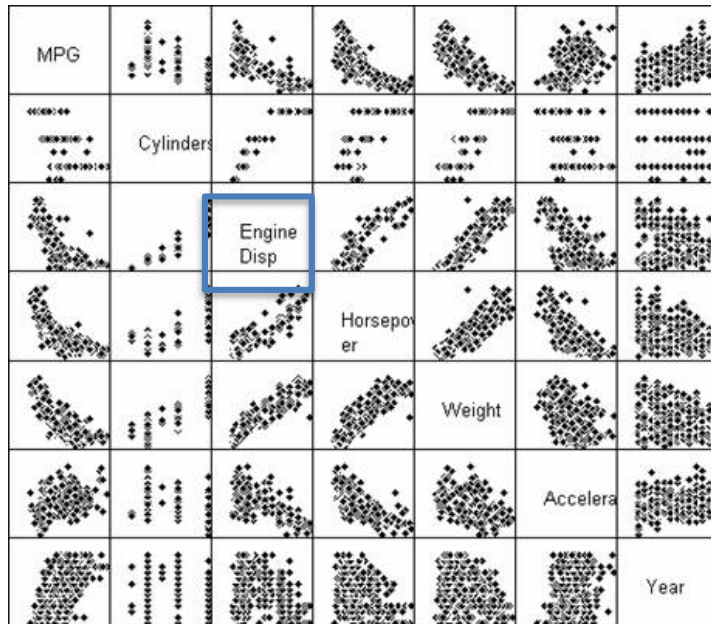

# OVERVIEW + DETAIL

## Browsing Multiple Views

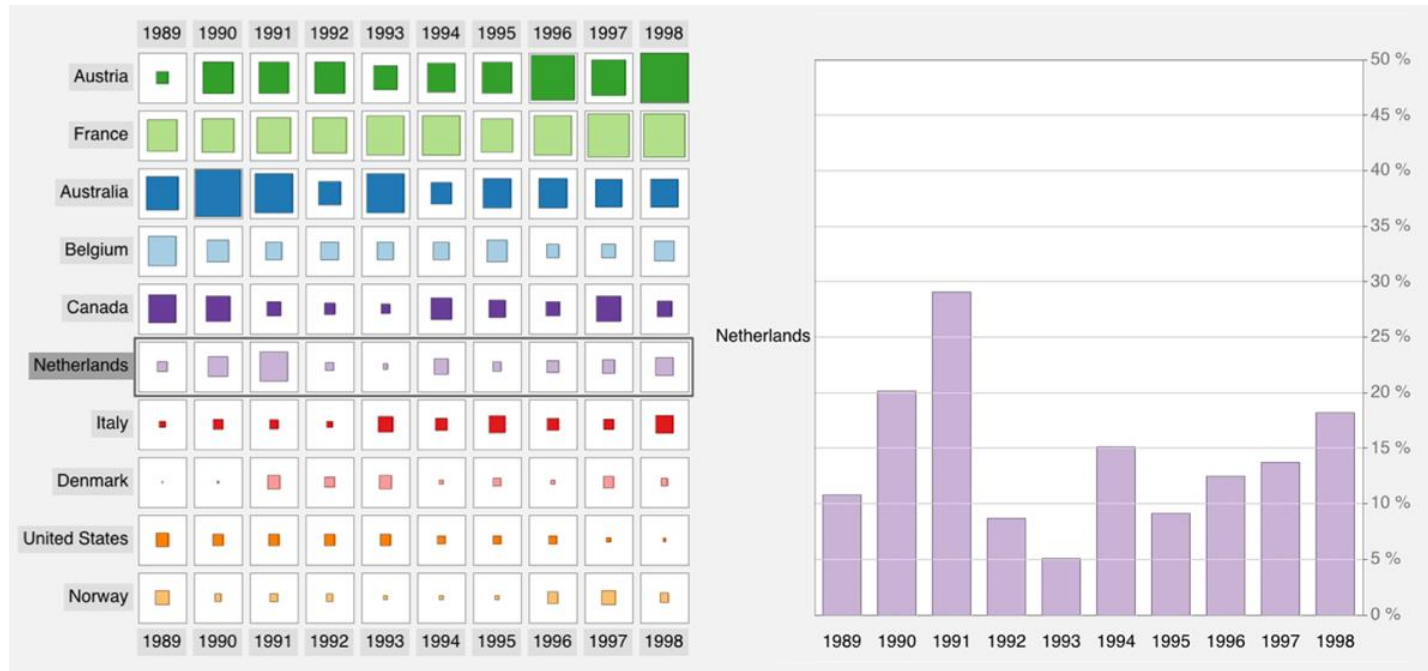

# FOCUS + CONTEXT

Space Distortion

1) Fisheye Views of Graphs

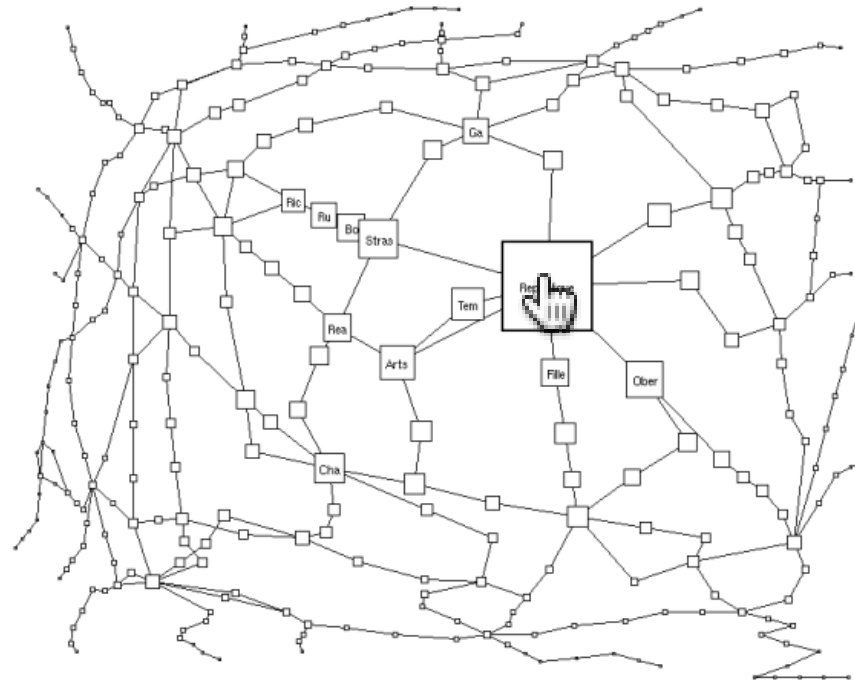



# FOCUS +

## Space Distortion 2) Fisheye Menus

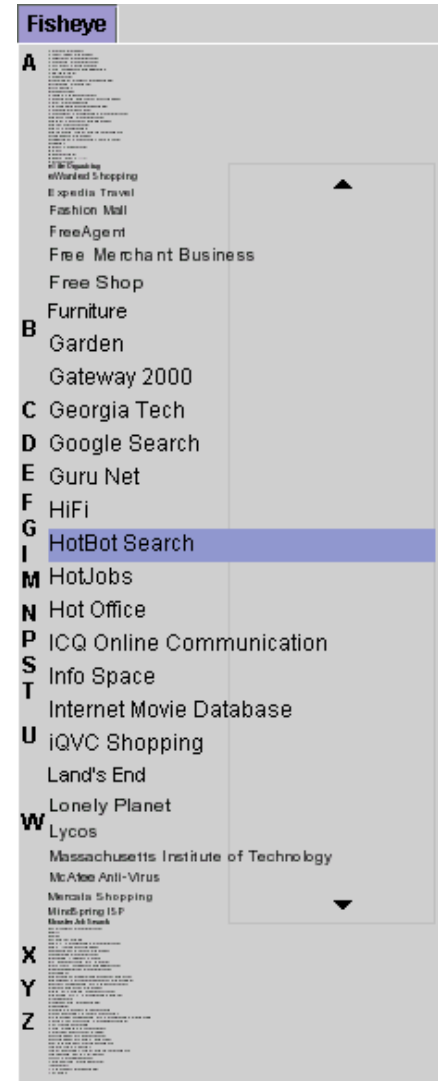

# FOCUS +

Space Distortion

3) Perspective Wall

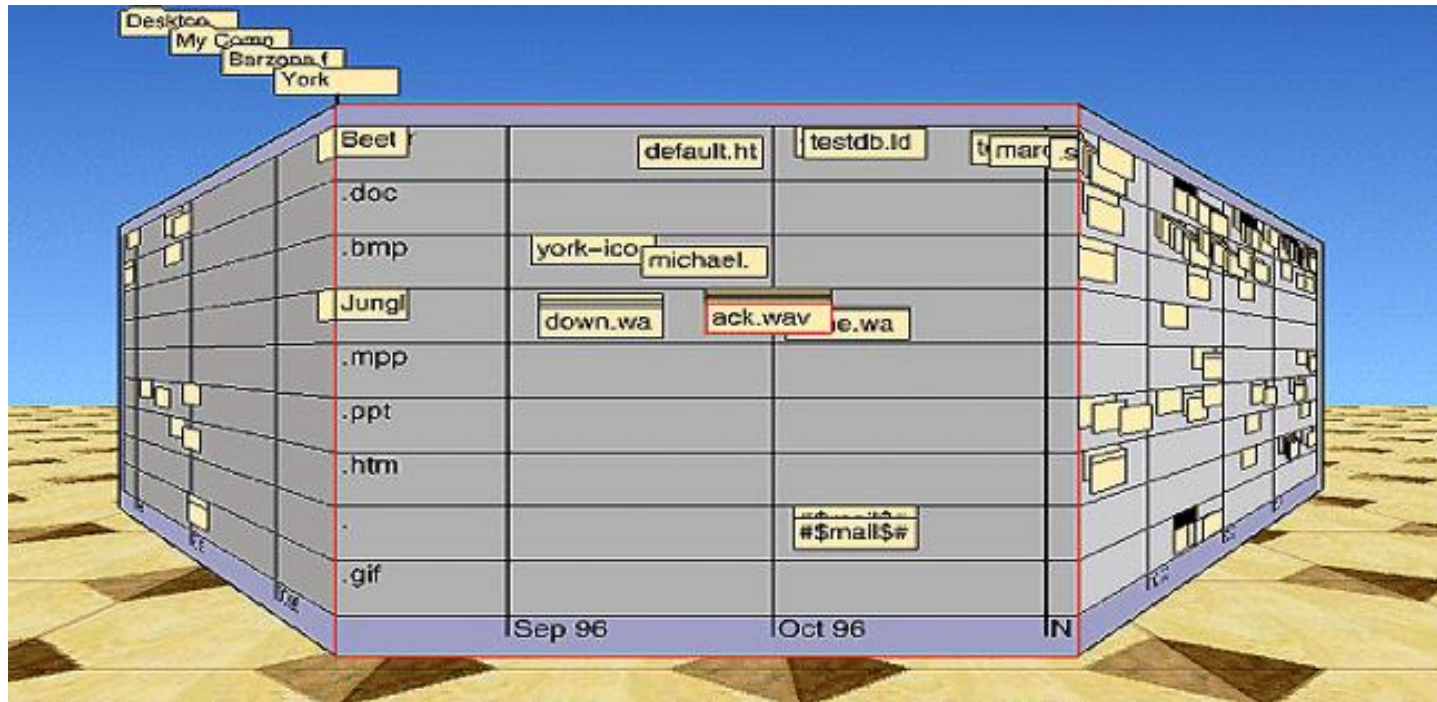

# FOCUS + CONTEXT

Space Distortion

4) Melange

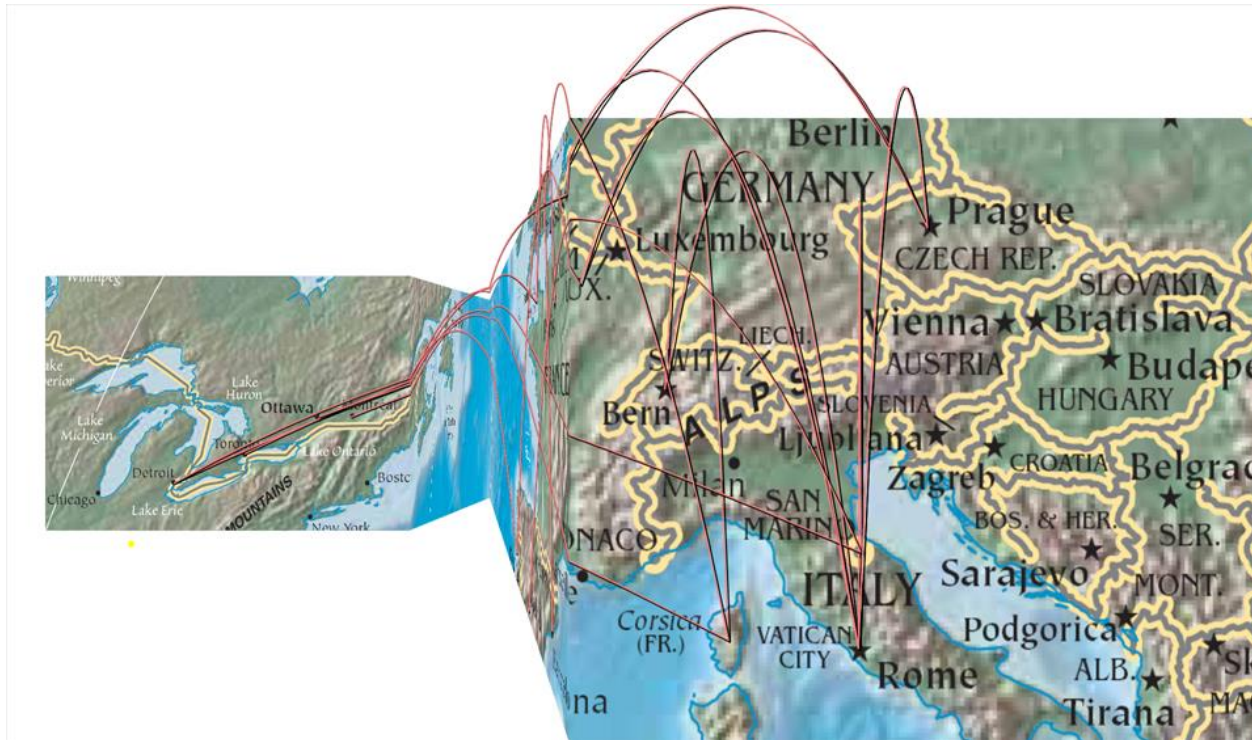

# Mélange

## Space-Folding for Multi-Focus Interaction

Niklas Elmqvist<sup>1</sup>, Nathalie Henry<sup>1,2,3</sup>, Yann Riche<sup>1,2,4</sup> and Jean-Daniel Fekete<sup>1</sup>  
<sup>1</sup>INRIA <sup>2</sup>LRI, Univ. Paris-Sud <sup>3</sup>University of Sydney <sup>4</sup>University of Queensland  
{elm, nhenry, riche, fekete}@lri.fr

# FOCUS +

- Space Distorsion
  - Melange

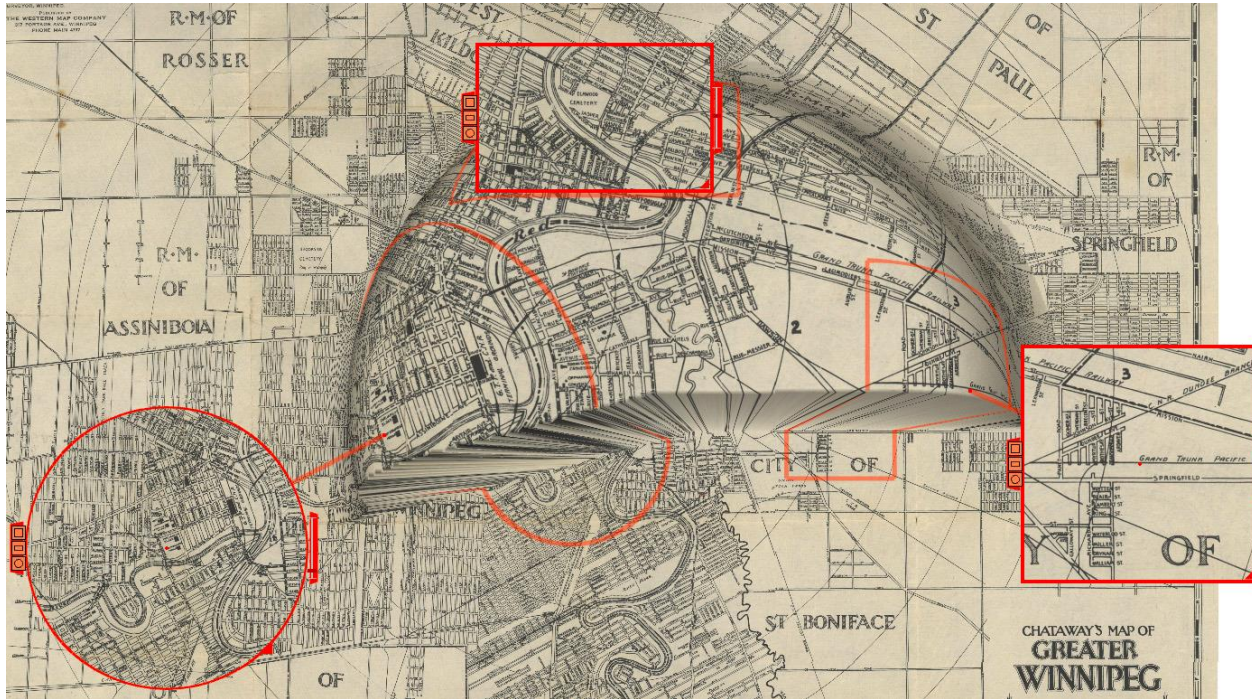



# FOCUS + CONTEXT

## Table Lens

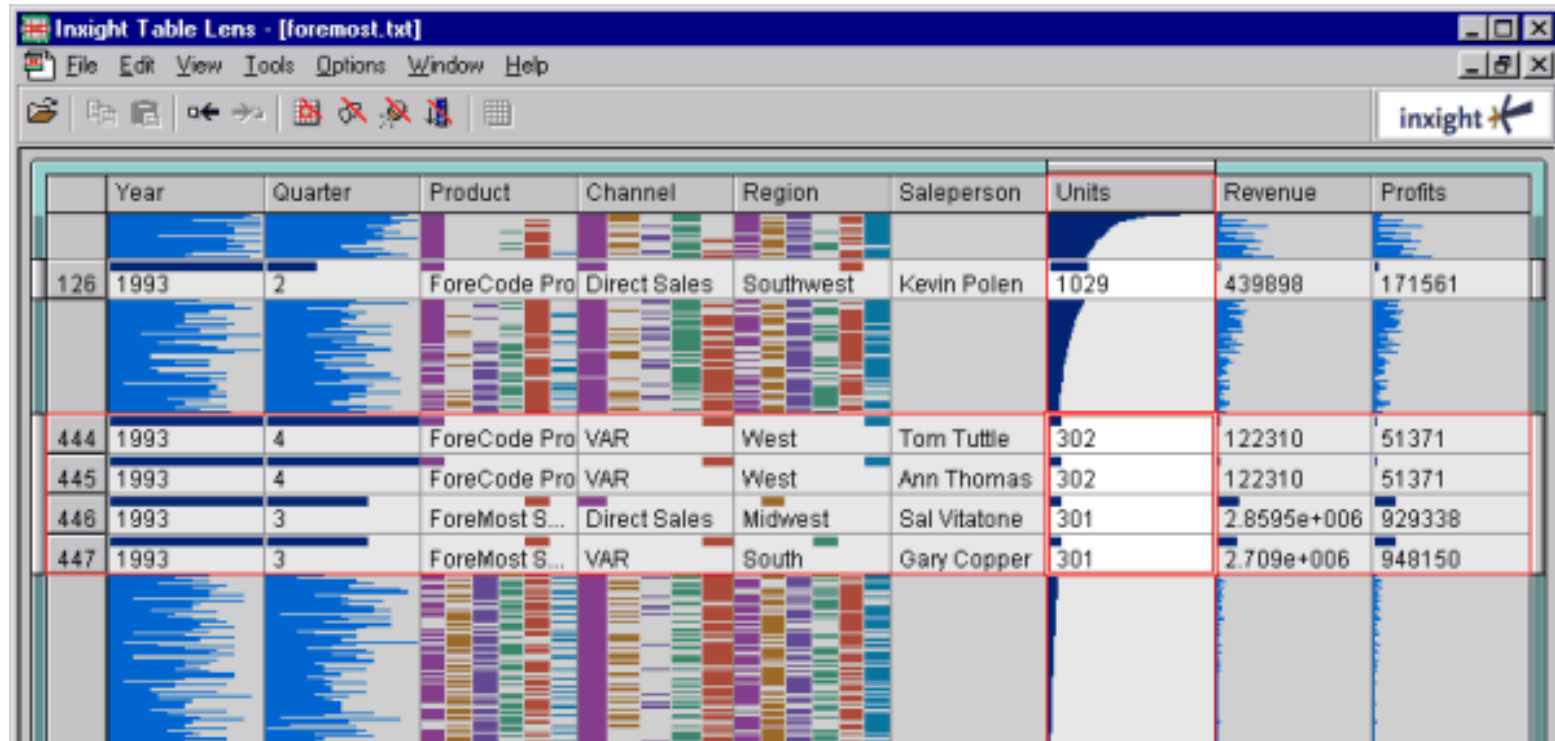

The screenshot shows the Inxight Table Lens application window. The title bar reads "Inxight Table Lens - [foremost.txt]". The menu bar includes "File", "Edit", "View", "Tools", "Options", "Window", and "Help". The toolbar contains various icons for navigation and editing. The main window displays a data table with columns: Year, Quarter, Product, Channel, Region, Salesperson, Units, Revenue, and Profits. A red rectangular lens highlights a specific row (row 444) and its corresponding data points in the Units, Revenue, and Profits columns. The lens also highlights the corresponding data points in the other columns for that row. The data in the highlighted row is as follows:

	Year	Quarter	Product	Channel	Region	Salesperson	Units	Revenue	Profits
126	1993	2	ForeCode Pro	Direct Sales	Southwest	Kevin Polen	1029	439898	171561
444	1993	4	ForeCode Pro	VAR	West	Tom Tuttle	302	122310	51371
445	1993	4	ForeCode Pro	VAR	West	Ann Thomas	302	122310	51371
448	1993	3	ForeMost S...	Direct Sales	Midwest	Sal Vitatone	301	2.8595e+006	929338
447	1993	3	ForeMost S...	VAR	South	Gary Copper	301	2.709e+006	948150

# FOCUS + CONTEXT

## Generalized Fisheye Views

(c) The Fisheye DOI:

$$\begin{aligned} \text{DOI}_{\text{fisheye}(\text{tree})}(x|y) &= \text{API}(x) - D(x,y) \\ &= -(d_{\text{tree}}(x,y) + d_{\text{tree}}(x,\text{root})) \end{aligned}$$

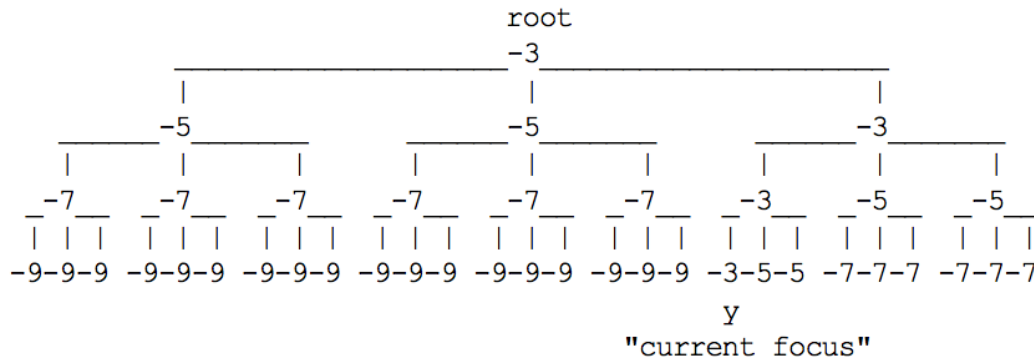



# FOCUS +

## Generalized Fisheye Views

**Pattern of Influence  
on the Observer:  
Fisheye Subset of  
entities**

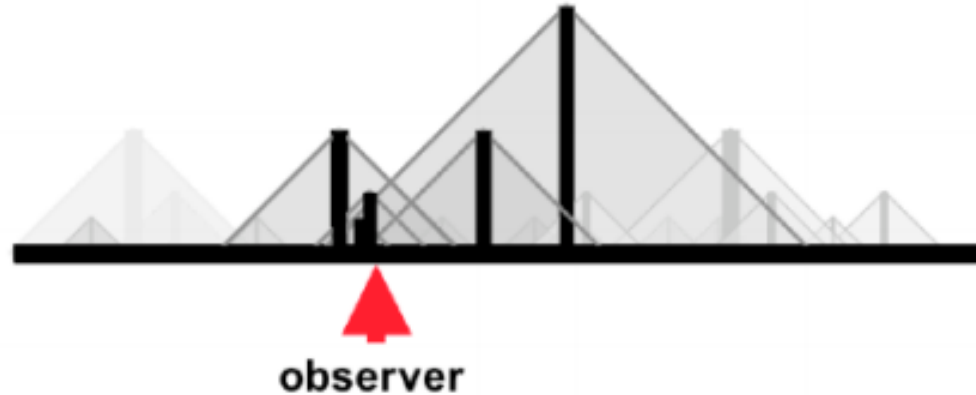

Furnas, 2010

A Fisheye Follow-Up: Further Reflections on Focus + Context

# MAGIC LENSES

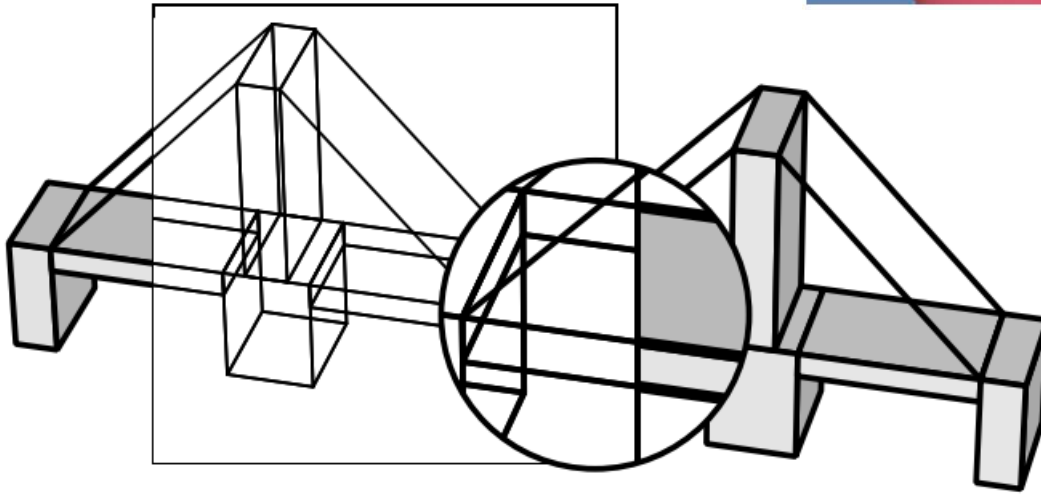
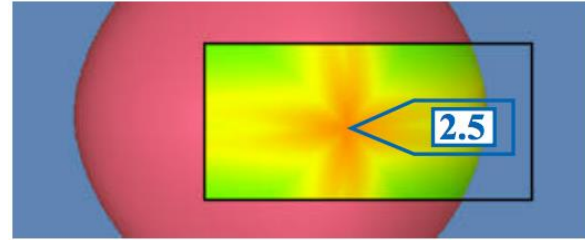

# MAGIC LENSES

Movable filters for dynamic queries

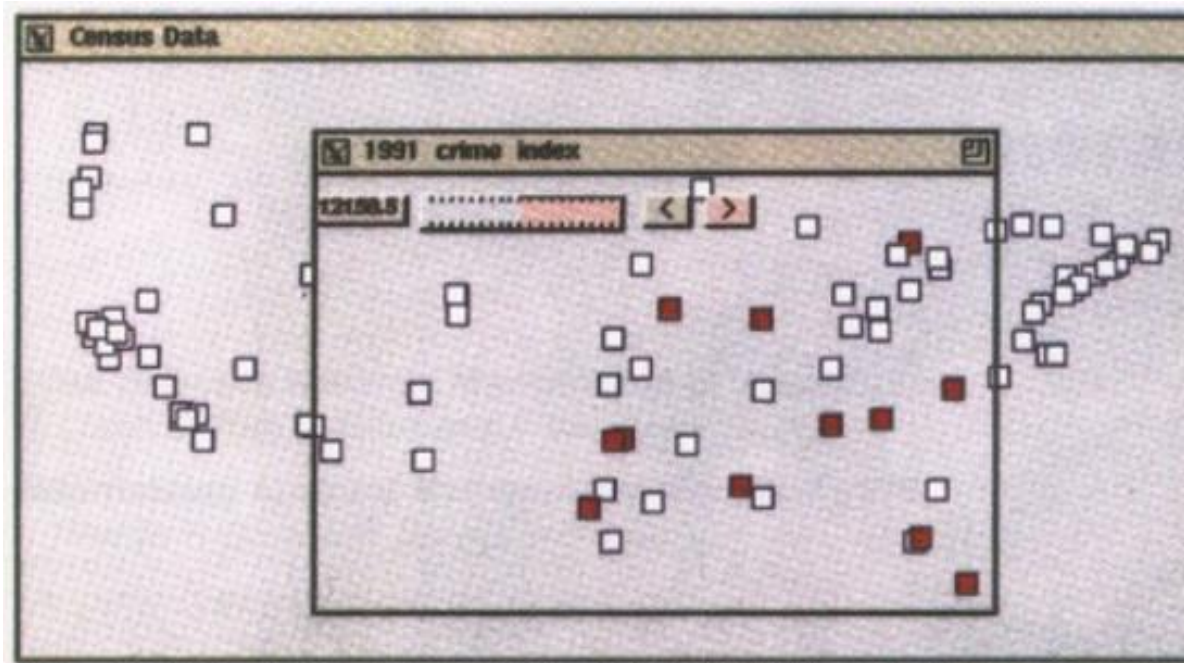

# MAGIC LENSES

## Exentric Labeling

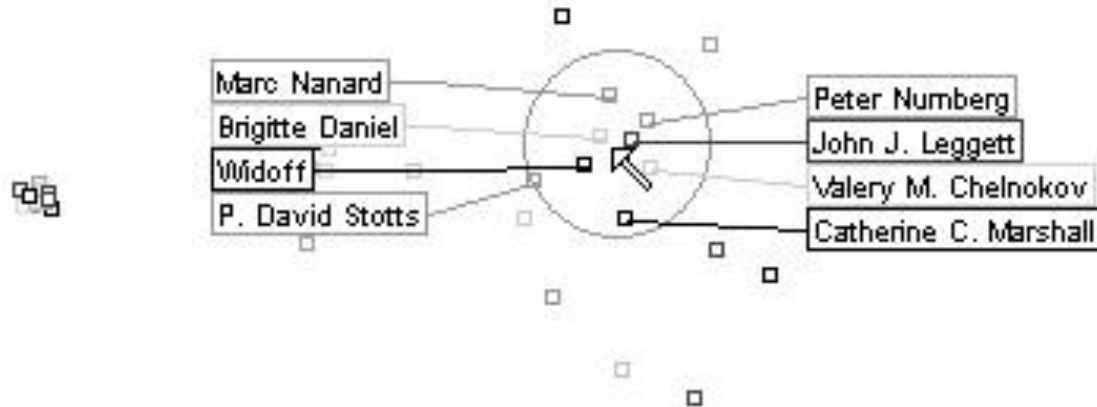

# MAGIC LENSES

## Edge lenses

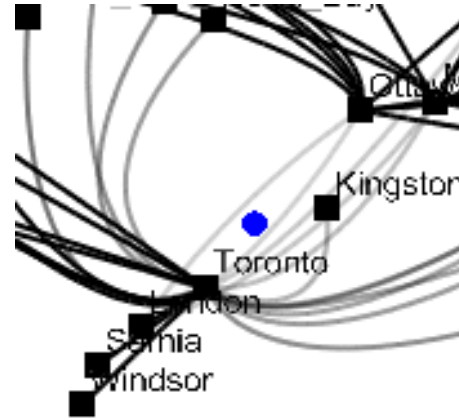

SELECT  
EXPLORE  
FILTER  
RECONFIGURE  
ENCODE  
ABSTRACT/ELABORATE

**CONNECT**

SHOW ME RELATED  
ITEMS

# BRUSHING AND LINKING

SELECT (“BRUSH”) A SUBSET OF DATA  
SEE SELECTED DATA IN OTHER VIEWS

THE COMPONENTS MUST BE *LINKED*  
BY *TUPLE* (MATCHING DATA POINTS),  
OR  
BY *QUERY* (MATCHING RANGE OR  
VALUES)

# BRUSHING AND LINKING

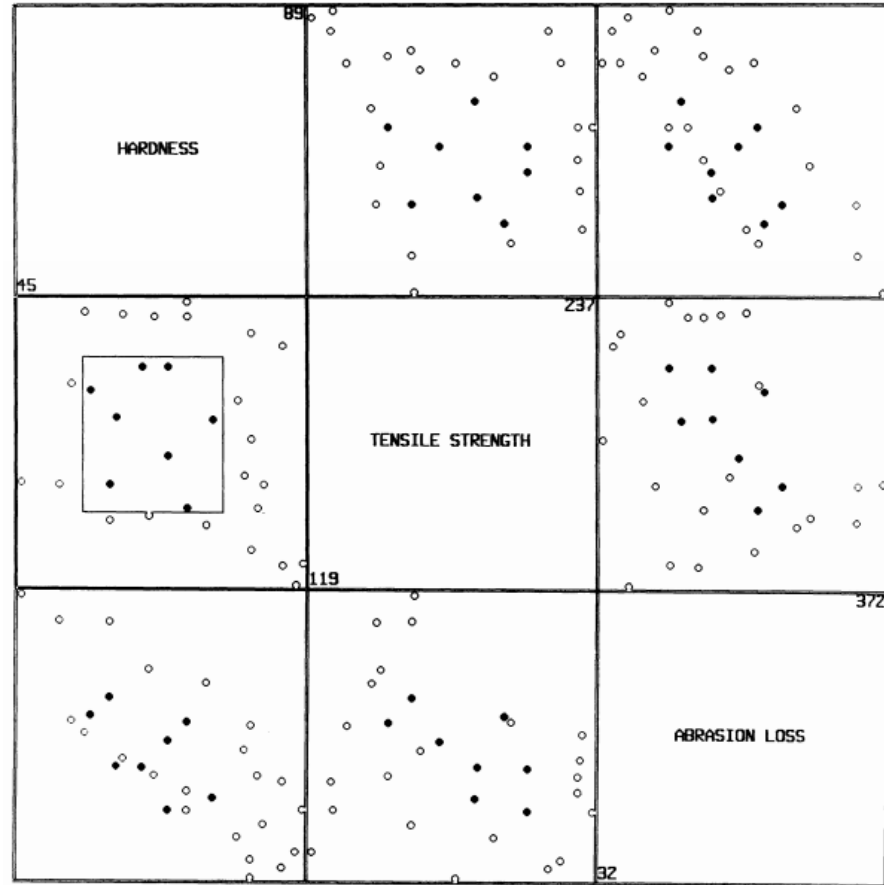

BRUSHING SCATTERPLOTS BECKER & CLEVELAND 1982



<p>100</p> <p>100</p>	<p>100</p> <p>100</p>	<p>100</p> <p>100</p>
<p>100</p> <p>100</p>	<p>100</p> <p>100</p>	<p>100</p> <p>100</p>
<p>100</p> <p>100</p>	<p>100</p> <p>100</p>	<p>100</p> <p>100</p>

# BRUSHING & LINKING

**HOW LONG  
IN MAJORS**

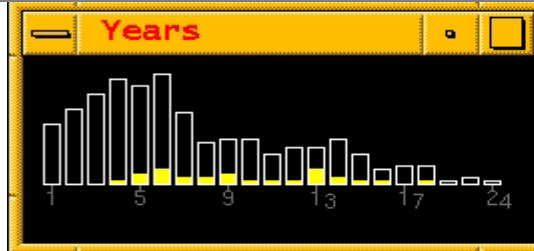

**SALARIES**

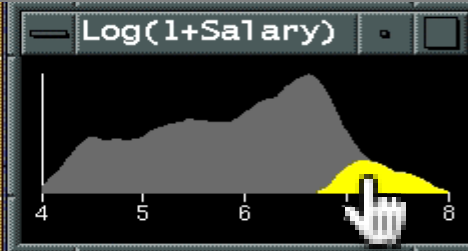

**ASSISTS VS  
PUTOUTS  
(FIELDING  
ABILITY)**

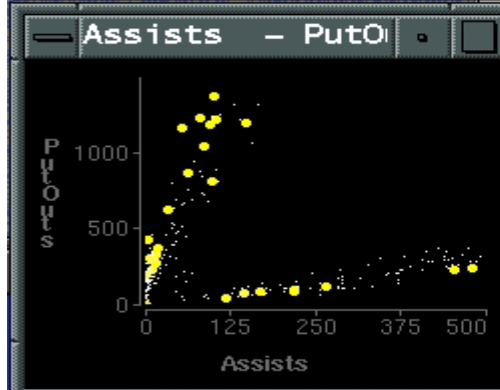

**HOME RUNS  
VS HITS  
(BATTING  
ABILITY)**

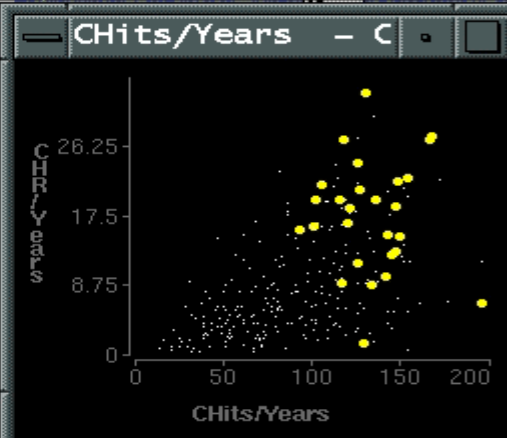

**DISTRIBUTION  
OF POSITIONS  
PLAYED**



# BRUSHING & LINKING

**HOW LONG  
IN MAJORS**

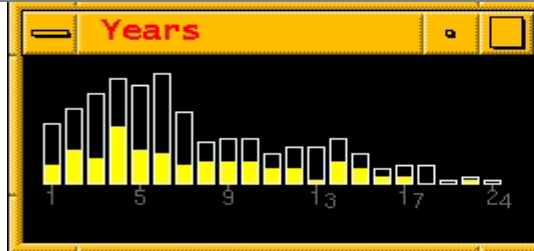

**SALARIES**

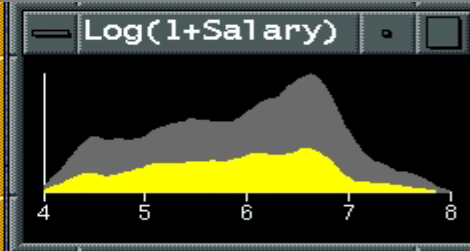

**ASSISTS VS  
PUTOUTS  
(FIELDING  
ABILITY)**

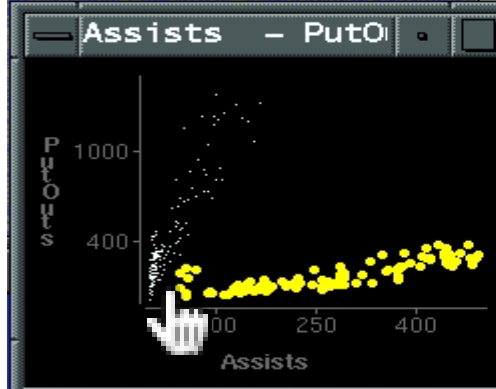

**HOME RUNS  
VS HITS  
(BATTING  
ABILITY)**

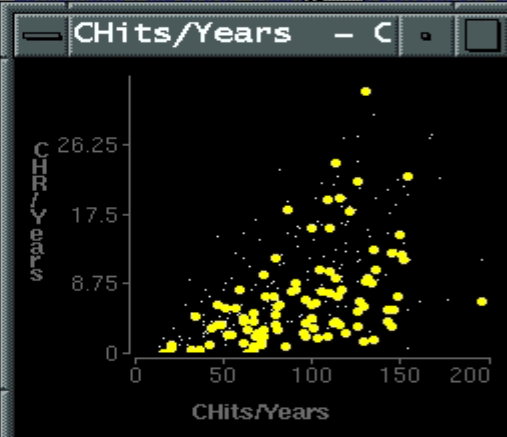

**DISTRIBUTION  
OF POSITIONS  
PLAYED**



# Generalized Selection via Interactive Query Relaxation

Jeffrey Heer | Maneesh Agrawala | Wesley Willett  
University of California, Berkeley

# SEVEN CATEGORIES OF INTERACTION BY INTENT

YI ET AL. 2007

SELECT

EXPLORE

FILTER

RECONFIGURE

ENCODE

ABSTRACT/ELABORATE

CONNECT

# TAXONOMIES OF

- What?
  - What is the user doing?
- Why?
  - Why is the user doing it?
- How?
  - How is the user doing it?

# HOW?

## INTERACTION TECHNIQUE

“An interaction technique is the fusion of **input and output**, consisting of all **software and hardware** elements, that provides a way for the user to accomplish a task”

(Tucker, 2004)

## TYPES OF INTERACTION TECHNIQUES

**Input:** mouse, touch, keyboard, speech,...

Shneiderman: **Command-line interfaces vs. Direct manipulation interfaces**

# HOW?

## INTERACTION TECHNIQUE

“An interaction technique is the fusion of **input and output**, consisting of all **software and hardware** elements, that provides a way for the user to accomplish a task”

(Tucker, 2004)

## TYPES OF INTERACTION TECHNIQUES

**Input:** mouse, touch, keyboard, speech,...

Shneiderman: **Command-line interfaces vs. Direct manipulation interfaces**

Beaudouin-Lafon: **Instruments** with different degrees of **directness**



# PITFALLS

## #1 - Interaction has a cost

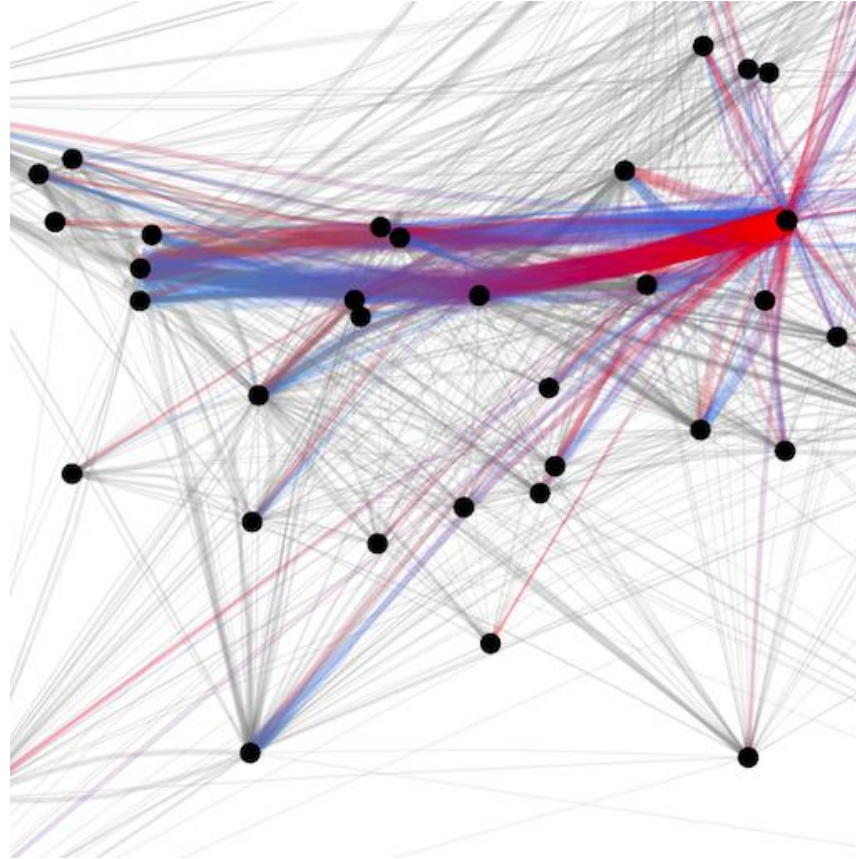

# PITFALLS

## #2 - Controls take screen real-estate

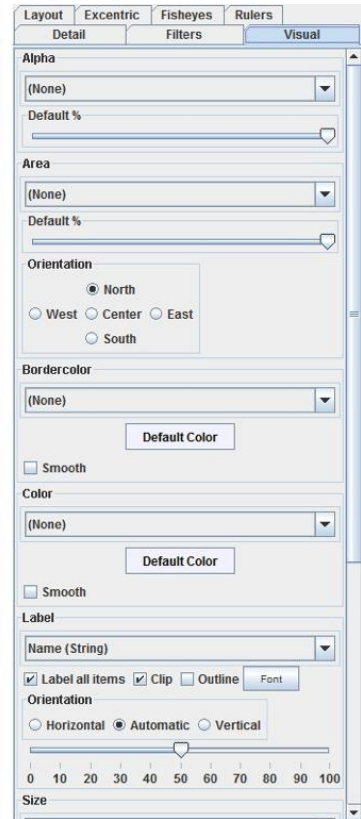
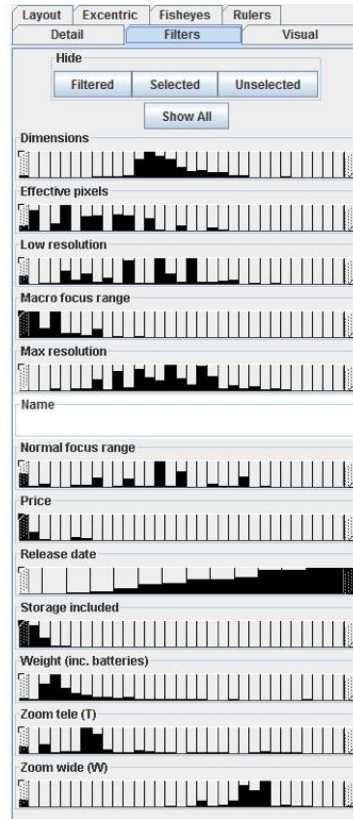
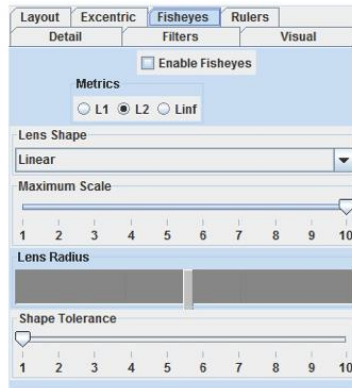
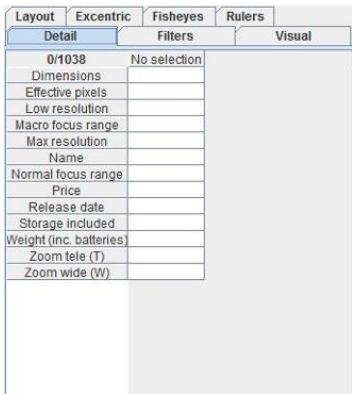
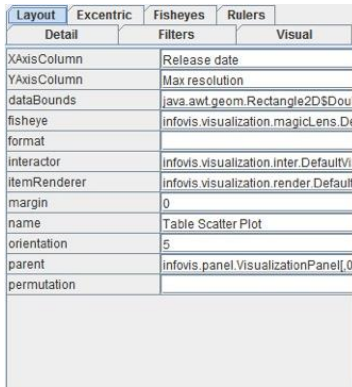

# PITFALLS

#3 - Few techniques are self-explanatory

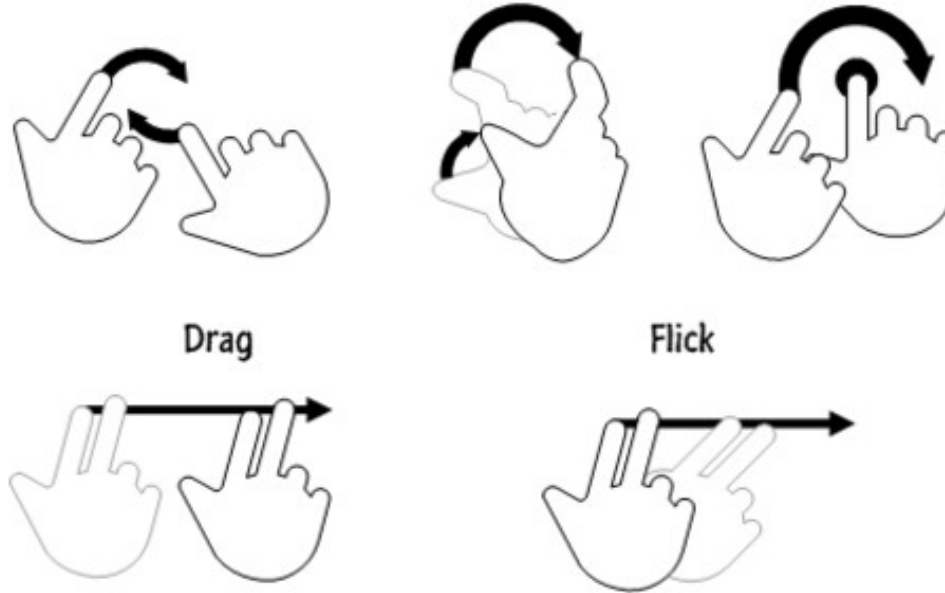

# GOING BEYOND THE DESKTOP

# TOUCH DEVICES

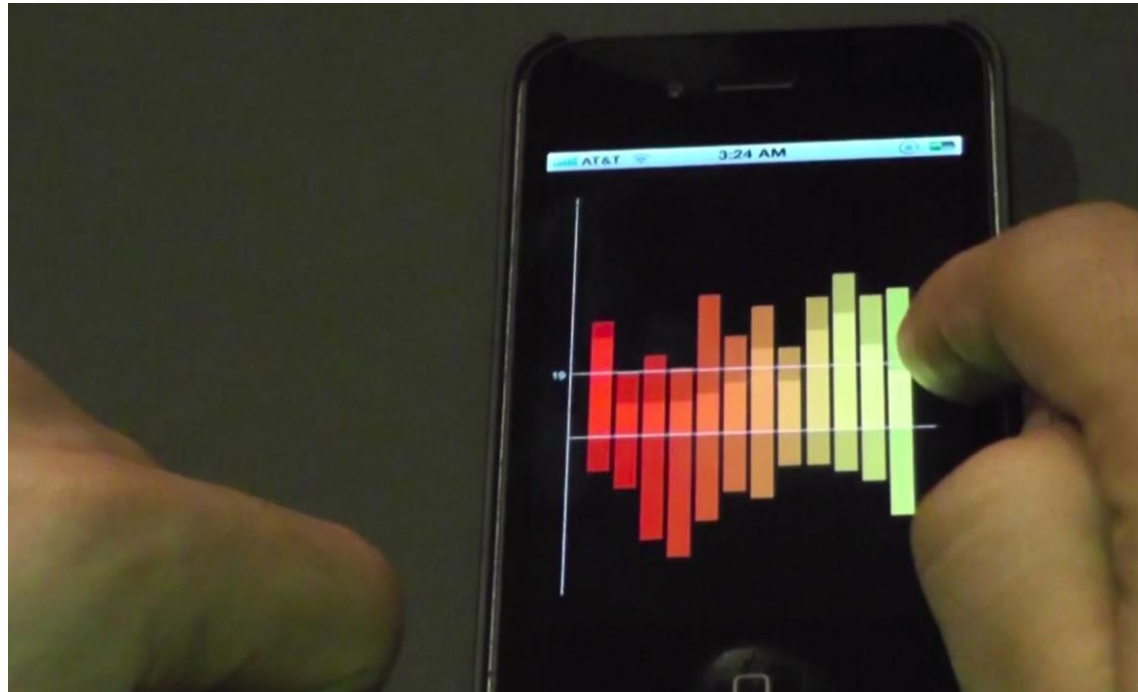

# TABLETOP



# WALL-SIZED









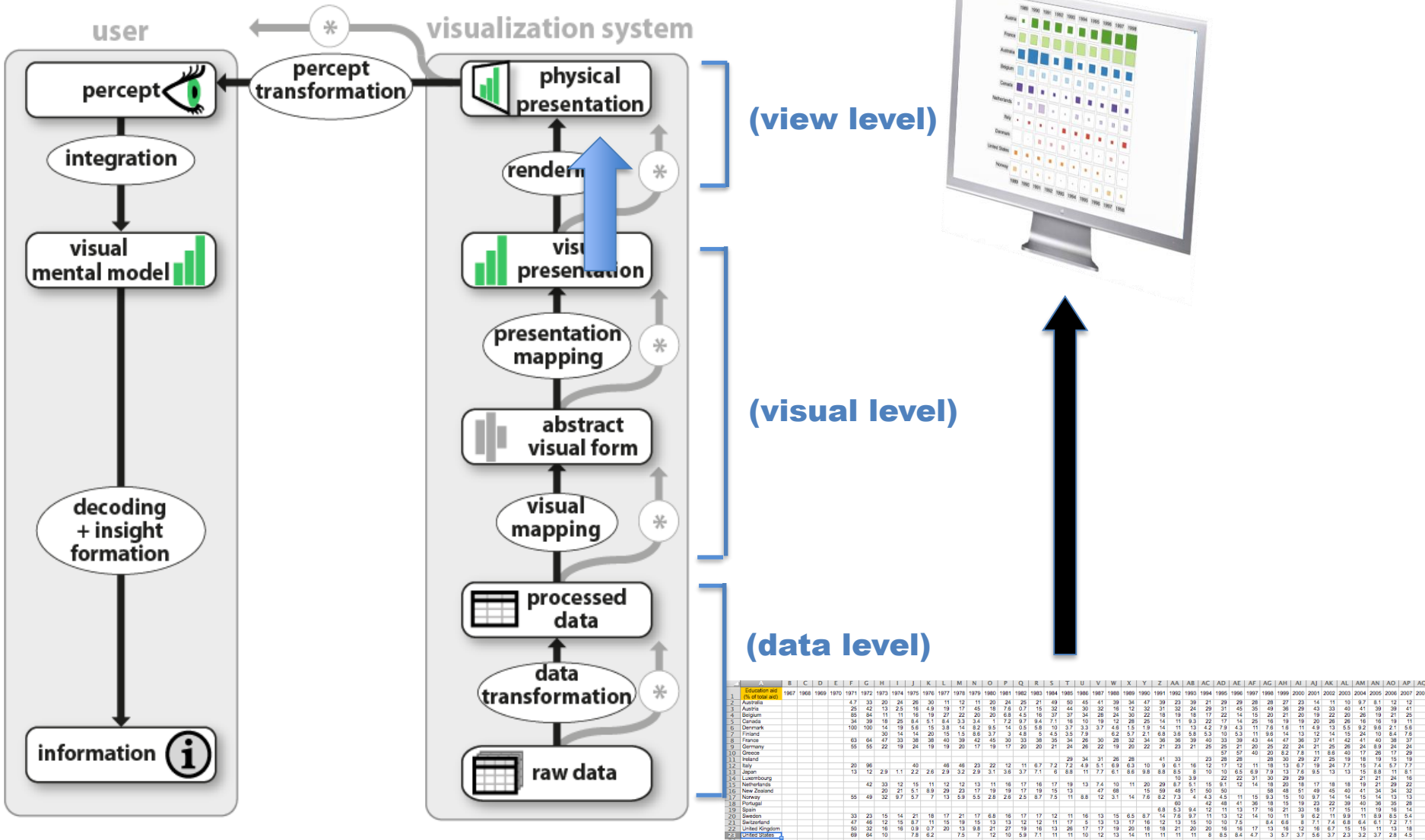

Evolution and % of total aid	1967	1968	1969	1970	1971	1972	1973	1974	1975	1976	1977	1978	1979	1980	1981	1982	1983	1984	1985	1986	1987	1988	1989	1990	1991	1992	1993	1994	1995	1996	1997	1998	1999	2000	2001	2002	2003	2004	2005	2006	2007	2008	
1. Austria	27	33	29	34	36	30	11	12	11	11	20	24	21	46	50	45	41	39	34	47	39	23	38	21	29	29	28	38	21	14	11	10	8,7	8,1	12	12	15						
2. Australia	25	42	13	2,5	16	4,9	19	17	45	18	7,6	0,7	15	32	44	30	32	16	12	32	31	32	24	29	31	45	35	49	36	29	43	33	40	41	39	39	41						
3. Canada	34	39	18	20	8,4	5,1	8,4	3,3	3,4	1,7	2,2	9,7	9,4	7,1	16	10	19	12	28	25	14	11	9,3	22	17	14	25	16	19	19	20	26	26	18	16	19	11						
4. Denmark	100	100	14	59	5,6	15	3,8	14	9,2	8,5	4,1	0,5	5,8	10	3,7	3,3	7,4	4,0	1,5	1,9	1,6	11	13	4,2	7,9	4,3	11	7,6	1,6	11	9,9	13	5,3	8,2	8,6	2,1	5,6						
5. Finland	30	14	14	20	15	1,5	0,6	3,7	3	4,8	5	4,5	3,5	7,9	6,2	5,7	2,1	6,8	3,8	5,8	5,3	10	5,3	11	8,6	14	13	12	14	15	24	10	8,4	7,6									
6. France	63	64	47	33	38	38	40	38	42	45	30	30	38	34	38	30	28	34	36	38	39	40	33	38	43	41	41	36	37	41	42	41	40	38	37								
7. Germany	55	55	22	19	24	19	19	20	17	19	17	20	20	21	24	26	22	18	20	22	21	21	25	25	21	25	22	24	21	25	26	24	8,9	24	7,6								
8. Greece																																											
9. Ireland																																											
10. Italy	20	36				40		48	48	25	22	12	11	6,7	7,2	7,2	4,8	5,1	6,9	6,3	10	8	6,1	18	12	17	12	11	18	13	6,7	16	24	7,7	18	7,9							
11. Japan	13	12	2,9	1,1	2,2	2,6	2,9	3,2	2,9	3,1	3,5	3,7	7,1	6	8,8	11	7,7	6,5	8,6	9,8	8,8	6,5	8	10	10	6,5	6,9	7,9	13	7,6	9,5	13	13	8,8	11	8,1							
12. Luxembourg																																											
13. Netherlands																																											
14. New Zealand	20	21	5,1	8,9	29	23	17	19	19	17	19	15	15	13	47	68	15	39	48	51	50	50	51	52	14	18	20	18	18	18	18	18	18	18	18	18	18	18	18	18	18		
15. Norway	55	49	32	9,7	5,7	7	13	5,8	5,5	2,6	2,6	2,5	8,7	7,5	11	8,8	12	3,1	14	7,6	8,2	7,3	4	4,8	4,5	11	15	9,3	15	10	8,7	14	14	14	14	14	14	14	14	14	14		
16. Portugal																																											
17. Spain																																											
18. Sweden	33	23	15	14	21	18	17	21	17	6,8	16	17	12	11	16	13	15	6,5	8,7	14	7,6	9,7	11	13	12	14	10	11	9	6,2	11	9,9	11	8,9	8,5	9,4							
19. Switzerland	47	48	12	35	8,7	11	10	19	16	13	13	12	12	11	17	5	13	13	17	16	12	13	15	10	10	7,5	8,4	6,8	8	7,1	7,4	6,8	6,4	6,1	7,2	7,1							
20. United Kingdom	50	32	16	18	0,9	0,7	20	13	9,8	21	27	19	16	13	26	17	17	19	20	18	18	21	20	20	18	16	17	13	16	12	16	6,7	15	11	13	13	18	18	18	18			
21. United States	69	64	10	7,8	6,2	7,5	7	12	10	5,9	7,1	11	11	11	16	12	13	14	11	11	11	11	11	11	11	8	8,5	8,4	4,7	3	6,7	3,7	5,6	3,7	2,3	3,2	3,7	2,8	4,5				
22. Other countries																																											

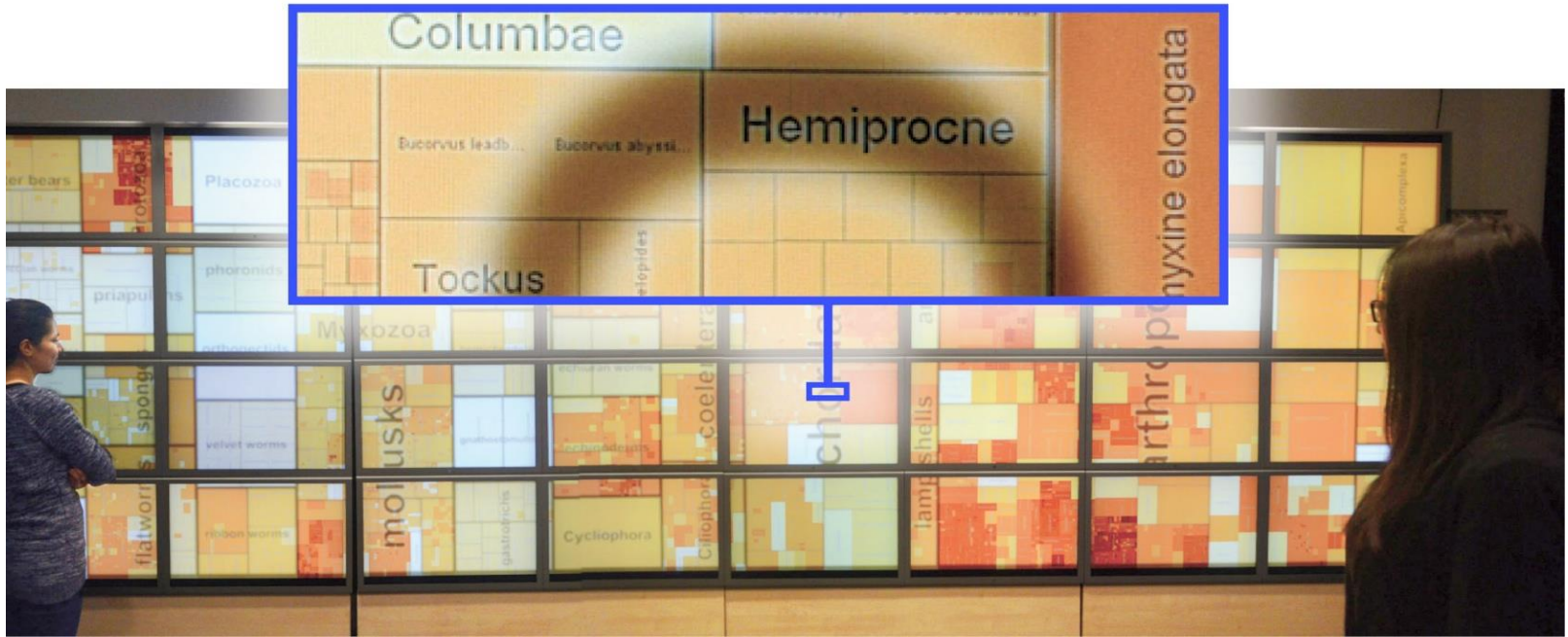

[Isenberg et al. , Hybrid Images for Large Viewing Environments, InfoVis'13]

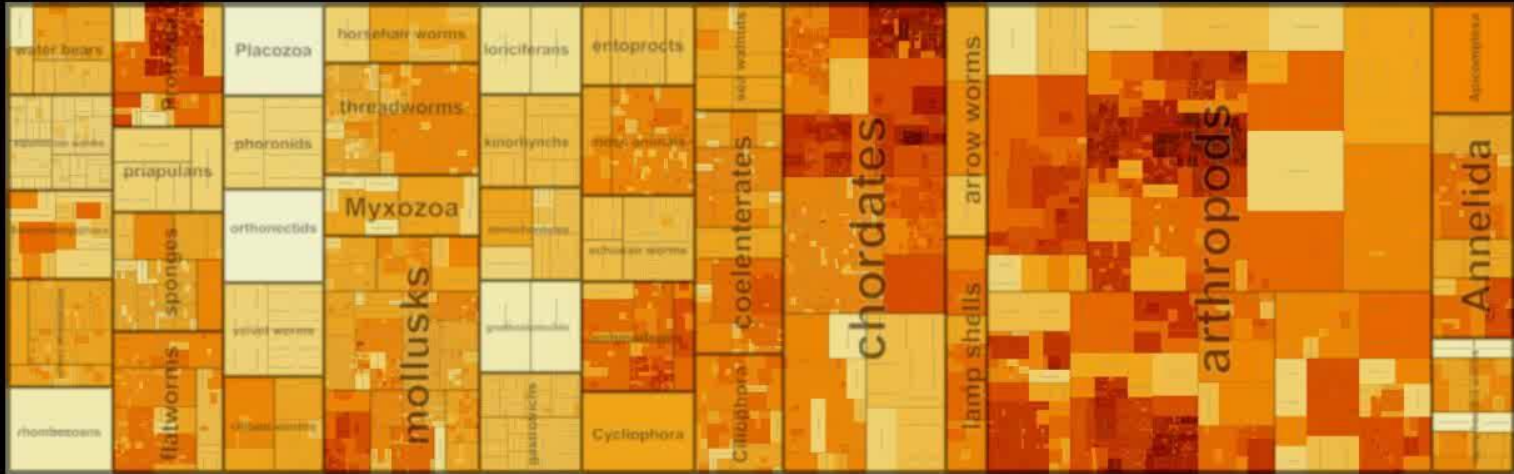

[Isenberg et al. , Hybrid Images for Large Viewing Environments, InfoVis'13]

# INTERACTION WITH THE PHYSICAL WORLD

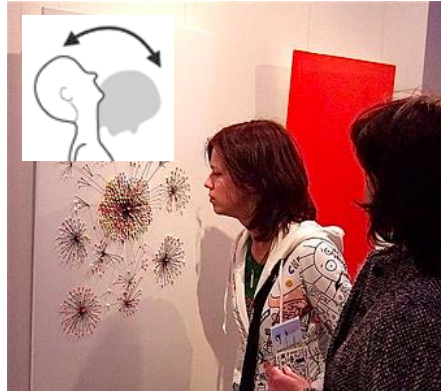
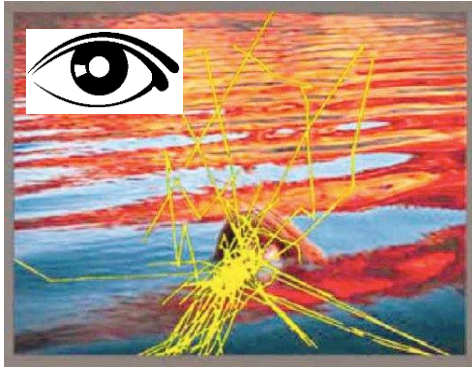

# PHYSICAL

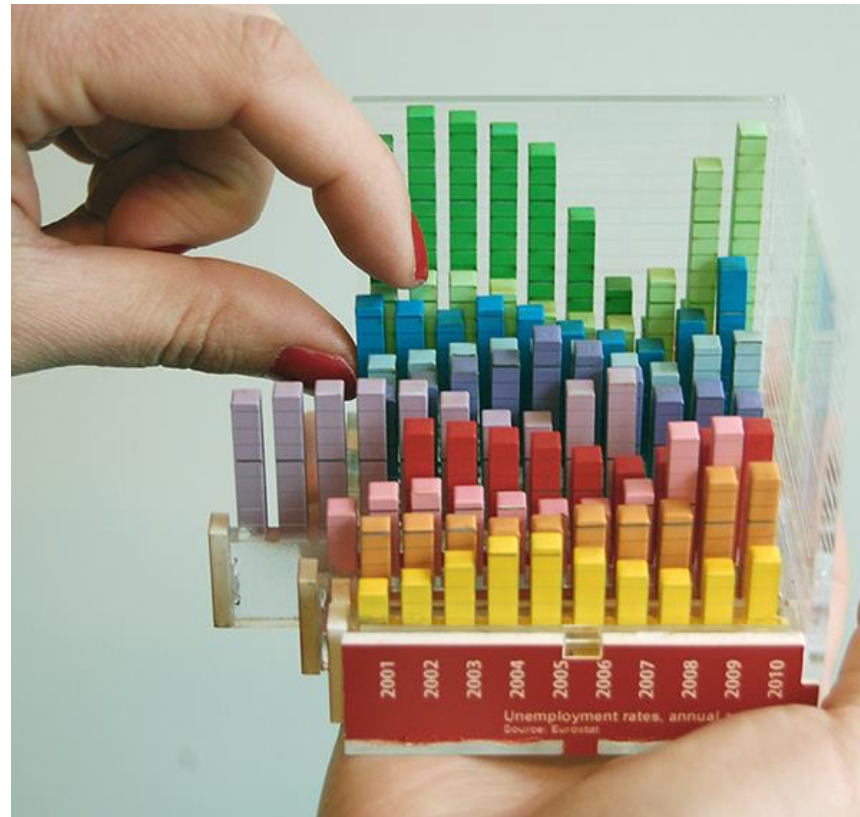

[tinyurl.com/physvis](http://tinyurl.com/physvis)

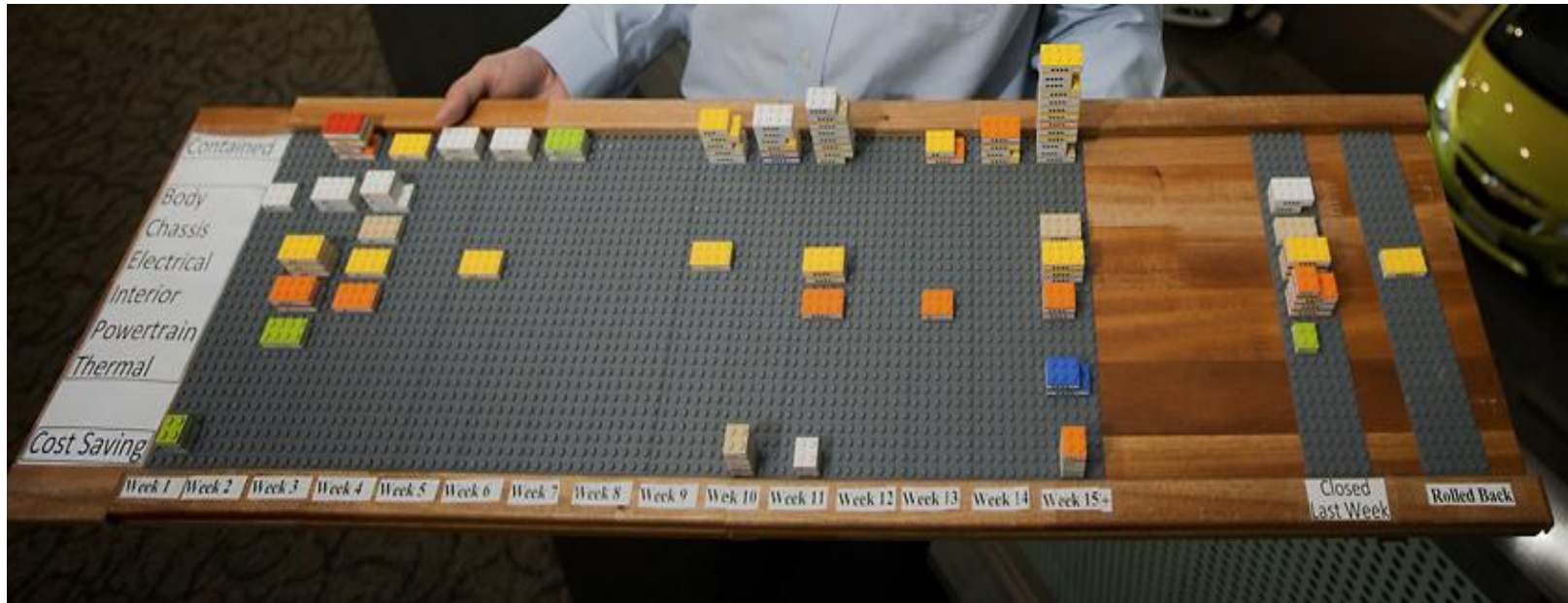

[Mark Wilson. How GM is saving cash using legos as a data viz tool. April 2012]

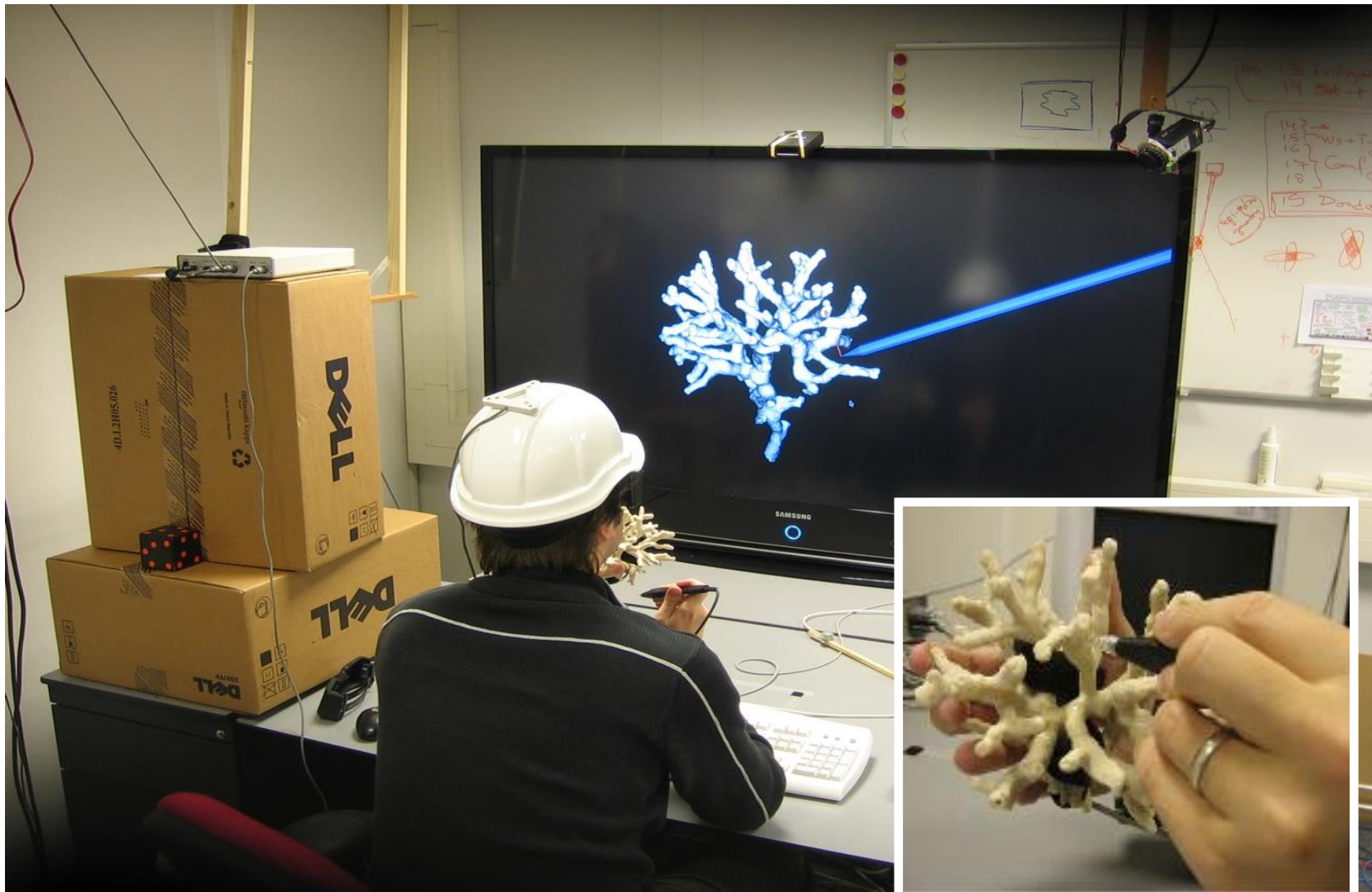

[Kruszynski & van Liere, Tangible Props for Scientific Visualization, Virtual Reality 13 (4) 2009]



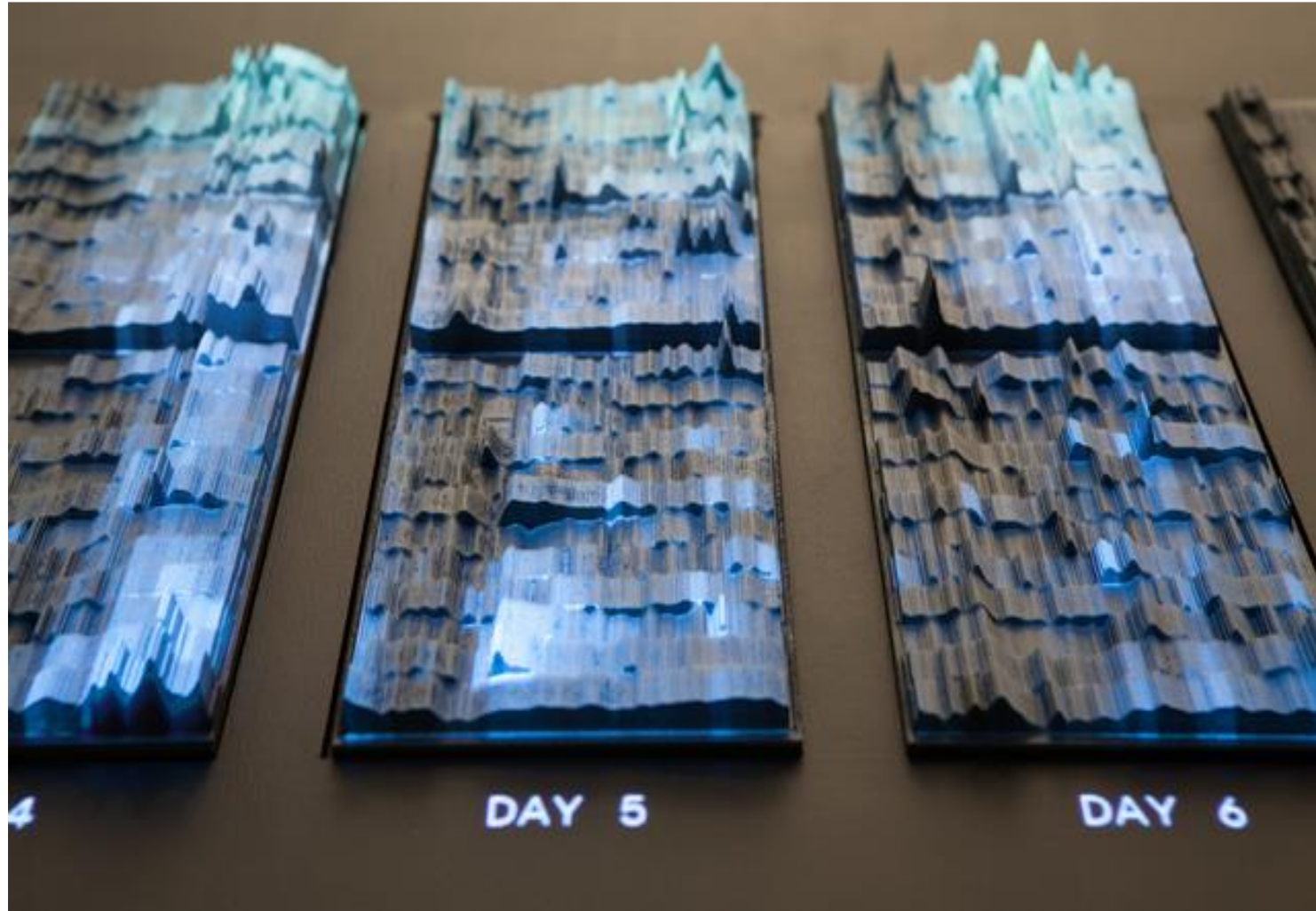

[Stefaner & Hemmert, emoto data sculpture, <http://www.nand.io/visualisation/emoto-installation>]

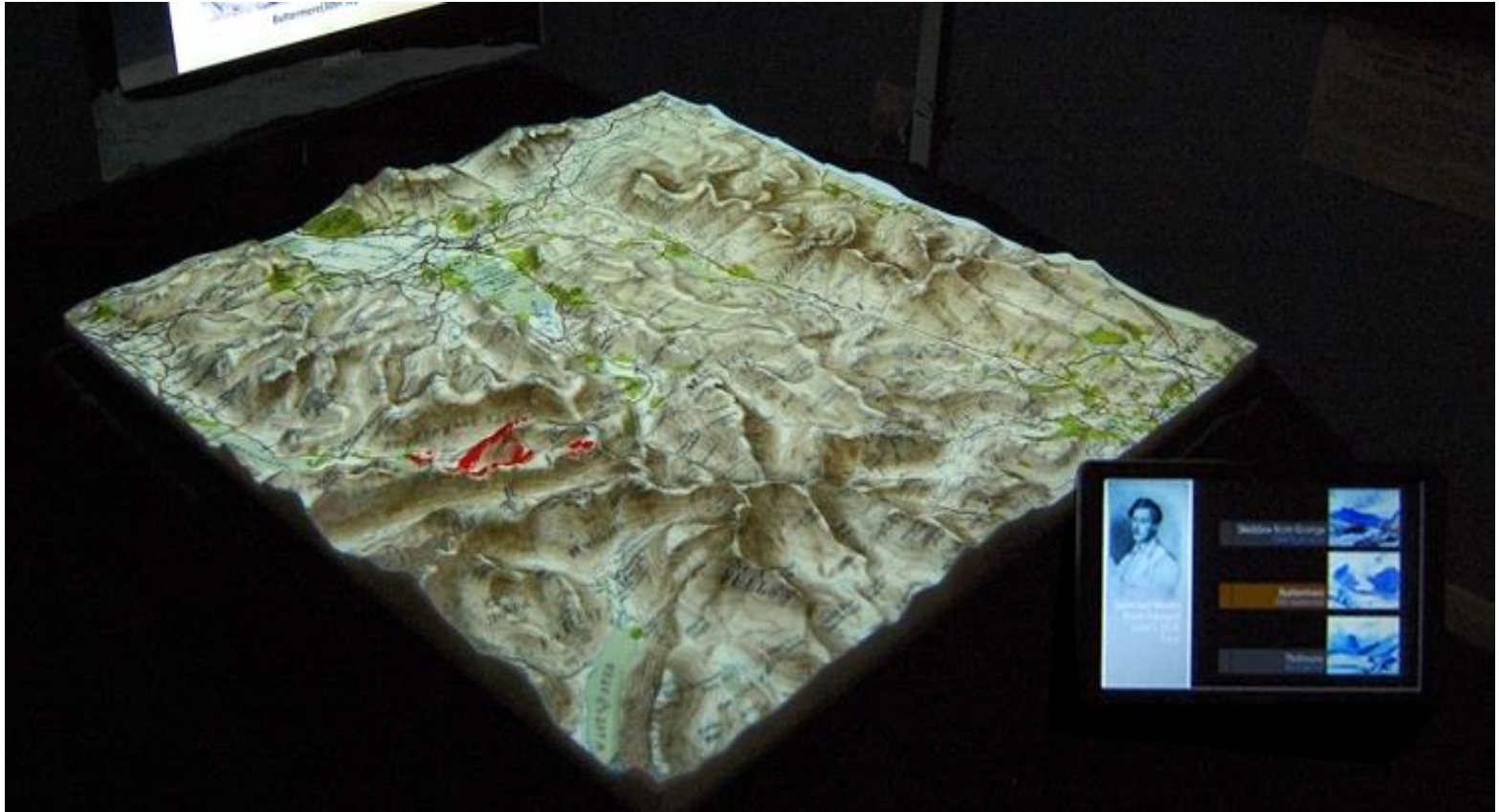

[PARM: Projected Augmented Relief Models, University of Nottingham, 2012]





# ACKNOWLEDGEMENTS

Slides in were inspired and adapted from slides by

- Wesley Willett (University of Calgary)
- Pierre Dragicevic (Inria)